

CELEBRATING
50
YEARS
maidaid®



Product GUIDE

Providing exceptional
warewashing since 1974

ISSUE
16

Valid from AUGUST 2024



Maidaid® Product Guide | Issue 16

Supplying professional catering equipment for 50 years

Maidaid® has achieved the impressive milestone of servicing the professional catering industry by supplying quality and cost effective products for fifty years.

The wealth of experience gained over the years has established Maidaid® as leaders within the industry. Our machines have a long standing reputation for durability and reliability.

Maidaid® products are constructed from the highest quality materials to ensure many years of commercial service. We produce a tough machine to do a tough job. Whether you want simple reliability or the very latest innovations in micro-processing, there is a Maidaid® machine for you.

What's more, we actually listen to our customers to help us provide what is, undoubtedly, the best service in the business.

That's why, in this Product Guide you will find every product is shown, together with its price, dimensions and relevant ancillary products.

You can also request the brochure in PDF format.

It has never been easier to select and order your Maidaid® equipment.



Contents

| | |
|--|--------------|
| Installation and General Conditions | 3 |
| On Site Commissioning and Guidance | 4 |
| Vision Statement | 5 |
| Support & Spares | 6 |
| C Range | 7-13 |
| Undercounter Glasswashers | 8 |
| Undercounter Glass/Dishwashers | 9 |
| Undercounter Tray/Dishwashers | 10 |
| Pass Through Glass/Dishwashers | 11-12 |
| C Range Ancillaries | 13 |
| C Range Glass & Dishwashers at a Glance | 13 |
| D Range | 15-19 |
| Undercounter Glasswashers | 16 |
| Undercounter Glass/Dishwashers | 17 |
| Pass Through Glass/Dishwashers | 18 |
| D Range Ancillaries | 19 |
| D Range Glass & Dishwashers at a Glance | 19 |
| Evolution Range | 21-28 |
| Undercounter Glass/Dishwashers | 22 |
| Undercounter Glass/Dishwashers | 23 |
| Pass Through Glass/Dishwashers | 24-25 |
| Evolution Range Ancillaries | 26 |
| Evolution Dishwashers with Power Consumption Control | 26 |
| Evolution Range Glass & Dishwashers at a Glance | 27 |
| C, D & Evolution Range Accessories | 29-30 |
| Tabling / Scrap Bin / Spray Arms | 30 |
| Warewashing Accessories | 31-34 |
| Baskets | 32-33 |
| Stands | 33 |
| Chemical Supplies | 34 |
| Rack and Flight Machines | 35-44 |
| Minirack Glass/Dishwashers | 36-37 |
| Minirack Tabling | 38 |
| RX Evo & Pro Rack Conveyors | 39-41 |
| RX Rack Conveyor Modules | 42 |
| RX Rack Conveyor Tabling | 43 |
| QX Flight Machines | 44 |
| UT Range | 45-48 |
| Utensil / Pot Washers | 46-47 |
| UT Range Ancillaries | 47-48 |
| Water Softeners & Ancillaries | 49-50 |
| Manual Water Softener | 50 |
| Twin Tank Battery Operated Automatic Salt Regenerated Softener | 50 |
| Automatic Salt Regenerated Softener | 50 |
| Icemakers | 51-62 |
| Cube Icemakers | 52 |
| Granular Icemakers | 53 |
| Pebble Icemakers | 54 |
| Half Dice Icemakers | 55 |
| Modular Cube Icemakers | 56-57 |
| Slim Bin Cube Icemakers | 58 |
| Slim Bin Storage Bins | 59 |
| Modular Storage Bins | 60 |
| Icemaker Ancillaries | 61-62 |

Assistance | installation & general conditions



assistance

Contact

For new orders and sales enquiries please email sales@maidaid-halcyon.co.uk

For all machine warranty enquiries please email service@maidaid-halcyon.co.uk

Tel: 0345 130 8070

Installation charges

| | |
|-------------------------------------|------|
| ● Undercounter glass or dishwasher | £285 |
| ● Hood / pass through dishwasher | £405 |
| ● Ice machine / Free standing | £340 |
| ● Ice machine modular | £POA |
| ● Utensil, rack & flight machines | £POA |
| ● Site survey prior to installation | £150 |
| ● Commissioning – see page 4 | £135 |

The above installation prices are for positioning and connection to all services within 1 metre, during normal working hours and are based on a clear site with unhindered access on the ground floor. Any minor modifications required to enable installation will be charged at cost.

Should the above not be available a **full site survey would be recommended** prior to installation.

Please note: An aborted install charge will result if the installation site has inappropriate provision of suitable service conditions or is unable to accept installation for any other reason that is not notified to us at least 24 business hours prior to the scheduled installation.

Ancillary items if fitted at time of installation

| | |
|---|------|
| ● Fit manual water softener | £75 |
| ● Fit hot or cold automatic water softener | £130 |
| ● To fit new or re-fit existing tabling (excluding any alterations) | £130 |
| ● Fit Ice machine independent drain pump | £70 |

Retro drain pump kits available on selected models – Price on application.

Ancillary pricing

Ancillary prices are correct at the point of print, but may vary, please contact our sales team for up to date pricing.

General conditions

Delivery, collection & disposal

Machine prices in this guide include free next working day delivery to mainland UK, excluding Rack/Flight, Pot/Utensil Washers and Modular Icemakers. Deliveries to certain destinations may have extended delivery period.

Delivery prices are for deliveries within 3 months of order. Orders delivered after 3 months will be subject to any current prices at time of delivery.

Prices for special delivery times or other destinations and excluded items delivery cost on request.

Standard delivery is limited to door step delivery only.



A collection & disposal service is available for UK mainland only. The cost for this is £95 for Undercounter machines and £125 for Pass Through models, subject to the machine being boxed, on a pallet and left in an easy to access area – this excludes Rack/Flight, Pot/Utensil washers & Modular ice makers which are subject to quotation.

Water treatment

To achieve good warewashing results water treatment is essential. It will help prevent calcium scaling of internal components and reduce detergent consumption. If water hardness exceeds 7° Clark (100 ppm), a water softener is recommended on all dish and glass washers, unless already built into the machine. Icemakers also suffer from scaling in hard water areas and in these cases a suitable replaceable water filter system must be used.

Warranty conditions

Warranty terms vary from one to three years and are stated throughout this guide, if not specifically referred to they are for 12 months. For warranty to remain valid, installation, commissioning and end user training must be completed per instructions supplied and within the specification of equipment; to fit suitable water treatment equipment in areas of hard water; to use recommended chemicals; and to operate the equipment in accordance with user instructions, which includes thoroughly cleaning equipment after use. For full warranty details please visit www.maidaid.co.uk.

VAT

All prices are subject to VAT at the current rate applicable at date of dispatch.



To ensure customers achieve the best results from their new equipment, Maidaid® respectfully request the notes below are read for guidance.

Getting the equipment set correctly for the environment in which it will be operated is vital. All products sold by Maidaid® should not be considered as plug and play.

All warewashing machines will require chemical dosing to be set correctly. Machines cannot be supplied ready adjusted to cope with the different concentrations of chemicals and different water quality in order to deal efficiently with the variety of items they have to wash.

Early staff training is highly recommended to achieve maximum productivity from staff and equipment.

Please ensure that you have ordered sufficient product racks to avoid problems in implementing the new equipment. Contact Maidaid® to ensure you are selecting the correct package for your requirements.

Conditions and requirements



Delivery

With the exception of the models listed below all prices include delivery to UK mainland. Delivery is to doorstep only, if a different service is required we will be happy to quote for that service.

Equipment that may be subject to delivery charge: Rack/Flight, Pot/Utensil Washers and Modular Ice makers.



Installation

Maidaid® is able to provide an installation service for all equipment in this Product Guide, please see page 3 or contact our office for current prices and conditions.



Commissioning

Machines must have been installed to a suitable standard and be ready to run. If an unsafe or unacceptable installation is found, commissioning will not be attempted and no credit of charges for commissioning will be made.



Training

Machines must be available as for commissioning and it must be assured that all staff to be trained are available at the prearranged time. Trainers cannot be asked to delay training beyond the agreed start time.



Proud to be celebrating **50 years** of dedicated service to our valued customers

1974 – 2024

OUR VISION

We aspire to transform the way the world cleans dishes by providing cutting-edge technology that delivers superior performance and convenience.

OUR PURPOSE

We strive to simplify daily chores, enhance cleanliness, and promote sustainable living by creating products that save time, energy, and water.

OUR MISSION

Our mission is to deliver innovative, quality-driven solutions that not only address current challenges but also anticipate and meet future needs.

We are committed to ensuring seamless operations for our customers, offering them an unrivalled focus on quality throughout every aspect of our products and services.

By fostering a culture of continuous improvement, we aspire to be the driving force behind positive industry transformation, setting the benchmark for excellence and reliability in our industry.

50 years supporting the industry



Sales support

- ✓ Multiple award winners for sales support voted as voted for by the industry
- ✓ All partners have full access to their designated Sales Manager
- ✓ Huge Stock levels with everything from undercounter right up to mini racks in stock
- ✓ **FREE OF CHARGE** Next Day Delivery anywhere in the UK¹
- ✓ 3pm cut off for all orders²
- ✓ Our commitment – we are so confident of having what you need that in the unlikely case we don't have the model you require, we will upgrade you for no additional cost!³
- ✓ **FREE OF CHARGE** multi-phase electric alterations to suit site requirements prior to delivery
- ✓ **FREE OF CHARGE** site survey
- ✓ **FREE OF CHARGE** on site staff training
- ✓ **FREE** full CAD design layouts/solutions for rack and flight machines
- ✓ Various promotions throughout the year

Technical & service support

- ✓ Multiple award winners for technical service support
- ✓ Full and direct access to our technical team
- ✓ Dedicated technical whatsapp – contact 01280 845333
- ✓ Bespoke In house triage system – Every breakdown call received is reviewed before allocating an engineer to prevent unnecessary call outs
- ✓ Unlimited access to all technical documents
- ✓ **FREE OF CHARGE** engineer training that is open to the industry
- ✓ Full in house workshop support
- ✓ National in house service coverage with robust dynamic vehicle stock
- ✓ Tailored Service support packages



caterparts®

- ✓ Caterparts are the Maidaids official warranty spares parts providers
- ✓ Specialist in supplying spare parts for all commercial catering equipment
- ✓ Large stock holding
- ✓ 5:30pm cut-off for next day delivery meaning you get what you need when you need it
- ✓ Tailormade van stocks available

¹ A small number of areas offer a limited service, whilst delivery will still be free it may not be next day. Excludes rack/flight, Pot/utensil washers & some modular ice machines.

² Machines requiring electrical configuration changes can be subject to an earlier cut off.

³ Limited to warewashing undercounter and hood machines only.



C Range

Undercounter Glasswashers
Undercounter Glass/Dishwashers
Pass Through Glass/Dishwashers





glasswashers

C Range

undercounter

Scan the QR code to view the C RANGE Undercounter Glasswasher operator training video



YouTube



C352

C402 & C405 WS

C452

C502

- **2 year warranty**
- C405 WS with **manual** internal regeneration water softener & drain pump as standard
- Four button bright LED display with soft touch controls, twin traffic lights giving instant status updates & operational self-diagnostics
- Alarms menu with hi-level information retrieval
- Improved wash action from quick release parallel wash & rinse arm design
- Surface scrap tray filters supplied as standard
- Fitted drain pump version available on C352, C402, C452 & C502*
- Three standard cycle time options with further options available
- Cycle times can be tailored to site requirements
- Automatic self-cleaning at end of service
- Selectable energy saving mode
- Selectable thermostop ensures optimum rinse temperatures
- Patented dual flow wash pump (excluding C352) – reducing power consumption whilst retaining wash efficiency
- Moulded wash tank for easy cleaning (excluding C452)
- Moulded rack guide giving partial double skin (excluding C452)
- Accurate detergent & rinse aid peristaltic dosing pumps as standard
- Supplied with two open cup/glass racks & cutlery insert

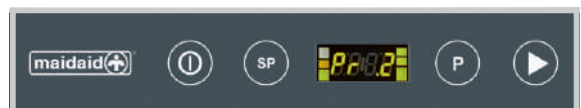

Four button bright LED display with soft touch controls & twin traffic lights giving instant status updates

Technical

- Standard voltage 230V – single phase
- C502 can be supplied 3 phase – **please specify at time of order**
- Suitable for hot (max 50°C) or cold water supply, typically at 2 to 4 bar dynamic supply pressure, refer to specification sheets for individual requirements
- Wash temperature 60°C (adjustable)
- Rinse temperature 65°C (adjustable)
- Cycle times between 70 & 240 secs, dependent on model

* Drain pump cannot be retro fitted to C502.

Drain pump versions require a waste up stand for correct operation.

Restrictive waste connections should be avoided for all installations.

All machines supplied 13 amp will come with moulded plug and cable.

Machines configured for 13 amp supply or fitted to cold water supply will not be capable of running repeated short cycles. The cycle time will automatically be extended to allow recovery of correct operating temperatures.

| Model | Rack size mm | Useable Height mm | Dimensions mm W x D x H | Cycle Options | Power kW | Amps Required | Price |
|----------------|--------------|-------------------|--------------------------------------|---------------|-------------|------------------------|---------------|
| C352 | 350 | 240 | 400 x 495 x 590 [†] | 3 Cycles | 2.8 | 13 | £2,010 |
| C352D | | | As C352 above with fitted drain pump | | | | £2,220 |
| C402 | 390 | 300 | 440 x 540 x 670 [†] | 3 Cycles | 2.8 | 13 | £2,450 |
| C402D | | | As C402 above with fitted drain pump | | | | £2,660 |
| C405 WS | 390 | 300 | 440 x 540 x 670 [†] | 3 Cycles | 2.8 | 13 | £2,970 |
| C452 | 450 | 280 | 525 x 560 x 705 [†] | 3 Cycles | 2.8 | 13 | £3,210 |
| C452D | | | As C452 above with fitted drain pump | | | | £3,370 |
| C502* | 500 | 340 | 580 x 610 x 810 [#] | 3 Cycles | 2.6/4.5/6.5 | 13/20/30 ^{##} | £3,810 |
| C502D | | | As C502 above with fitted drain pump | | | | £4,060 |

[†] Height excludes adjustable feet which will add 5 to 15mm. [#] Height excludes adjustable feet which will add 10 to 20mm.

^{##} Machines will be supplied for 30 amp supply as standard. If supplied 13 amp machine will come fitted with moulded plug and cable.

20 amp machines will be supplied with original cable and without plug. Standard 13 amp UK 3 pin plugs will be **unsuitable** for cable supplied.

See page 13 for ancillary items.

C Range | undercounter



C512



C525 WS



Scan the QR code to view the C RANGE Undercounter Dishwasher operator training video YouTube

- **2 year warranty**
- Four button bright LED display with soft touch controls, twin traffic lights giving instant status updates & operational self-diagnostics
- Alarms menu with hi-level information retrieval
- Improved wash action from quick release parallel wash & rinse arm design
- Improved range of water hardness settings on C525 WS
- C525 WS with **automatic** continuous internal water softener and drain pump as standard
- Supplied with breaktank as standard
- Fitted drain pump version available on C512*
- Three standard cycle time options with further options available
- Cycle times can be tailored to site requirements
- Reduced water consumption
- Automatic self-cleaning at end of service
- Selectable energy saving mode
- Selectable thermostop ensures optimum rinse temperatures
- Patented dual flow wash pump – reducing power consumption whilst retaining wash efficiency
- Moulded wash tank for easy cleaning
- Moulded rack guide giving partial double skin
- Surface scrap tray filters supplied as standard
- Accurate detergent & rinse aid peristaltic dosing pumps as standard
- Supplied with one pegged rack, one open cup/glass rack & cutlery insert

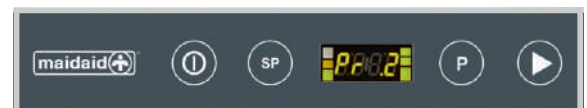

Four button bright LED display with soft touch controls & twin traffic lights giving instant status updates

Technical

- Standard voltage 230V – single phase (can be supplied for 3 phase – **please specify at time of order**)
- Suitable for hot (max 50°C) or cold water supply, typically at 2 to 4 bar dynamic supply pressure, refer to specification sheets for individual requirements
- Wash temperature 60°C (adjustable)
- Rinse temperature 82°C (adjustable)
- Cycle times between 70 & 240 secs, dependent on model

* Drain pump cannot be retro fitted to C512.

Drain pump versions require a waste up stand for correct operation.

Restrictive waste connections should be avoided for all installations.

All 500 basket machines supplied 13 amp will come with moulded plug and cable.

Machine configured for 13 amp supply or fitted to cold water supply will not be capable of running repeated short cycles. The cycle time will automatically be extended to allow for recovery of correct operating temperatures.

| Model | Rack size mm | Useable Height mm | Dimensions mm W x D x H | Cycle Options | Power kW | Amps Required | Price |
|----------------|--------------|-------------------|--------------------------------------|---------------|-------------|---------------|---------------|
| C512* | 500 | 340 | 580 x 610 x 810# | 3 Cycles | 2.6/4.5/6.5 | 13/20/30## | £4,070 |
| C512D | | | As C512 above with fitted drain pump | | | | £4,320 |
| C525 WS | 500 | 340 | 580 x 610 x 810# | 3 Cycles | 2.6/4.5/6.5 | 13/20/30## | £4,620 |

Height excludes adjustable feet which will add 10 to 20mm.

Machines will be supplied for 30 amp supply as standard. If supplied 13 amp machine will come fitted with moulded plug and cable. 20 amp machines will be supplied with original cable and without plug. Standard 13 amp UK 3 pin plugs will be **unsuitable** for cable supplied.

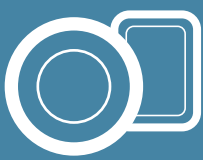

C Range | undercounter



C612 & C615 WS

C652
(shown with tray insert
– not included)

S/S CONTAINER INSERTS

MH101491B

Capacity 5 x 1/1
gastronom
containers –
maximum
depth 65mm

£222.00



MH103454B

Capacity 8 x 1/1
gastronom
containers –
maximum
depth 40mm

£187.84

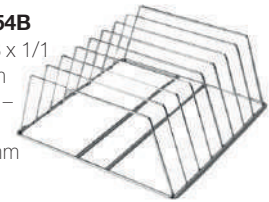

- **2 year warranty**
- C612 & C615 WS undercounter 500 x 600 rack, tray/dishwashers
- C652 front loader 500 x 600 rack, tray/dishwasher
- Four button bright LED display with soft touch controls, twin traffic lights giving instant status updates & operational self-diagnostics
- Alarms menu with hi-level information retrieval
- Enhanced wash action from quick release triple wash & rinse arm design
- Stainless steel surface scrap tray filters supplied as standard
- C615 WS with **automatic** continuous internal water softener
- Drain pump & breaktank supplied as standard
- Range offers a substantial usable height of 375mm to cater for large washware
- Three standard cycle time options with further options available
- Cycle times can be tailored to site requirements
- Automatic self-cleaning at end of service
- Selectable energy saving mode
- Selectable thermostop ensures optimum rinse temperatures
- Patented dual flow wash pump with **soft start** – reducing power consumption whilst retaining wash efficiency
- Moulded wash tank for easy cleaning
- Moulded rack guide giving partial double skin
- Accurate detergent & rinse aid peristaltic dosing pumps as standard
- Supplied with one 500 x 600 pegged rack & one 500 x 500 open rack
- Compatible with 500 x 500 racks

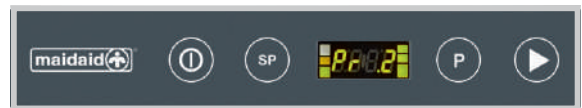

**Four button bright LED display with soft touch controls
& twin traffic lights giving instant status updates**

Technical

- Standard voltage 230V – single phase (can be supplied for 3 phase – **please specify at time of order**)
- Suitable for hot (max 50°C) or cold water supply, typically at 2 to 4 bar dynamic supply pressure, refer to specification sheets for individual requirements
- Wash temperature 60°C (adjustable)
- Rinse temperature 82°C (adjustable)
- Cycle times between 70 & 240 secs, dependent on model

Requires a waste up stand for correct operation. Restrictive waste connections should be avoided for all installations.

Machines supplied 13 amp will come with moulded plug and cable.

Machines configured for 13 amp supply will not be capable of running repeated short cycles. The cycle time will automatically be extended to allow for recovery of correct operating temperatures.

| Model | Rack size mm | Useable Height mm | Dimensions mm W x D x H | Cycle Options | Power kW | Amps Required | Price |
|----------------|--------------|-------------------|-------------------------------|---------------|-------------|------------------------|---------------|
| C612 | 500 x 600 | 375 | 580 x 700 x 840 [#] | 3 Cycles | 2.8/4.7/6.7 | 13/20/30 ^{##} | £5,800 |
| C615 WS | 500 x 600 | 375 | 580 x 700 x 840 [#] | 3 Cycles | 2.8/4.7/6.7 | 13/20/30 ^{##} | £6,320 |
| C652 | 500 x 600 | 375 | 580 x 700 x 1100 [†] | 3 Cycles | 2.8/4.7/6.7 | 13/20/30 ^{##} | £6,530 |

[#] Height excludes adjustable feet which will add 10 to 20mm. [†] Height excludes adjustable feet which will add 135 to 195mm.

^{##} Machines will be supplied for 30 amp supply as standard. If supplied 13 amp machine will come fitted with moulded plug and cable.

20 amp machines will be supplied with original cable and without plug. Standard 13 amp UK 3 pin plugs will be **unsuitable** for cable supplied.

See page 13 for ancillary items.

C Range | pass through



Scan the QR code to view the C RANGE Pass Through Dishwasher operator training video
[YouTube](#)

C2011
 (shown with tabling – not included)

C2035 WS
 (shown with tabling – not included)

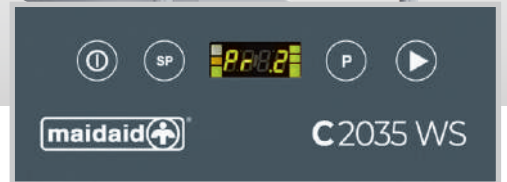

Four button bright LED display with soft touch controls & twin traffic lights giving instant status updates

- **2 year warranty**
- Four button bright LED display with soft touch controls, twin traffic lights giving instant status updates & operational self-diagnostics
- Alarms menu with hi-level information retrieval
- Improved wash action from quick release parallel wash & rinse arm design
- Easy lift soft glide hood system
- C2035 WS with drain pump as standard and improved internal **automatic** continuous water softener design with increased range of water hardness settings
- Supplied with breaktank as standard
- Fitted drain pump version available on C2011*

- Three standard cycle time options with further options available
- Cycle times can be tailored to site requirements
- Automatic self-cleaning at end of service
- Selectable energy saving mode
- Selectable thermostop ensures optimum rinse temperatures
- Patented dual flow wash pump – reducing power consumption whilst retaining wash efficiency
- Moulded wash tank for easy cleaning
- Surface scrap tray filters supplied as standard
- Accurate detergent & rinse aid peristaltic dosing pumps as standard
- Supplied with one pegged rack, one open cup/glass rack & cutlery insert

Technical

- Standard voltage 230V – single phase (can be supplied for 3 phase – **please specify at time of order**)
- Suitable for hot (max 50°C) or cold water supply, typically at 2 to 4 bar dynamic supply pressure, refer to specification sheets for individual requirements
- Wash temperature 60°C (adjustable)
- Rinse temperature 82°C (adjustable)
- Cycle times between 70 & 240 secs

* Drain pump cannot be retro fitted to C2011.

Drain pump versions require a waste up stand for correct operation.

Restrictive waste connections should be avoided for all installations.

Machines fitted to cold water supply will not be capable of running repeated short cycles. The cycle time will automatically be extended to allow for recovery of correct operating temperatures.

| Model | Rack size mm | Useable Height mm | Dimensions mm W x D x H | Cycle Options | Power kW | Amps Required | Price |
|-----------------|---------------------------------------|-------------------|-------------------------|---------------|----------|---------------|---------------|
| C2011* | 500 | 435 | 640 x 745 x 1500# | 3 Cycles | 4.5/6.5 | 20/30## | £6,390 |
| C2011D | As C2011 above with fitted drain pump | | | | | | £6,680 |
| C2035 WS | 500 | 435 | 640 x 745 x 1500# | 3 Cycles | 4.5/6.5 | 20/30## | £7,020 |

Height adjustable from 1500 to 1560mm (hood closed), 1980 to 2040mm (hood open). Height includes adjustable legs.

Machines will be supplied for 30 amp supply as standard, if 20 amp required specify at time of order.

It is strongly recommended that 500mm machines are installed on hot water fill (max 50°C) for optimum performance.



C Range | pass through + heat recovery

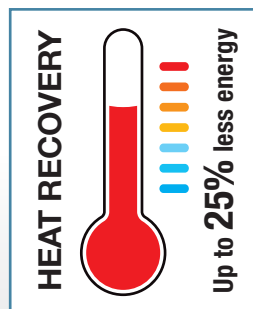

C2035 WS HR
(shown with tabling –
not included)



Scan the QR
code to view the
C RANGE
Pass Through
Dishwasher
operator
training video
 YouTube

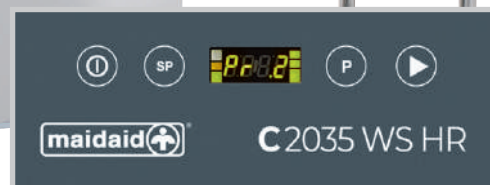

Four button bright LED display with soft touch controls
& twin traffic lights giving instant status updates

- 2 year warranty
- **HEAT RECOVERY** offers up to 25% less power required to heat rinse water
- HR module supplied separately with simple bolt on instructions
- Reduces need for extraction hood and improves working environment
- C2035 WS HR with heat recovery, drain pump and improved internal **automatic** continuous water softener design with increased range of water hardness settings as standard
- Four button bright LED display with soft touch controls, twin traffic lights giving instant status updates & operational self-diagnostics
- Alarms menu with hi-level information retrieval
- Improved wash action from quick release parallel wash & rinse arm design on both models
- Easy lift soft glide hood system
- Supplied with breaktank as standard

- Three standard cycle time options with further options available
- Cycle times can be tailored to site requirements
- Automatic self-cleaning at end of service
- Selectable energy saving mode
- Selectable thermostop ensures optimum rinse temperatures
- Patented dual flow wash pump – reducing power consumption whilst retaining wash efficiency
- Moulded wash tank for easy cleaning
- Surface scrap tray filters supplied as standard
- Accurate detergent & rinse aid peristaltic dosing pumps as standard
- Supplied with one pegged rack, one open cup/glass rack & cutlery insert

Technical

- Standard voltage 230V – single phase (can be supplied for 3 phase – **please specify at time of order**)
- Suitable for cold water supply only, typically at 2 to 4 bar dynamic supply pressure, refer to specification sheets for individual requirements.
Cannot be used with hot water supply.
- Wash temperature 60°C (adjustable)
- Rinse temperature 82°C (adjustable)
- Cycle times between 70 & 240 secs

Requires a waste up stand for correct operation. Restrictive waste connections should be avoided for all installations.

Machines fitted to cold water supply will not be capable of running repeated short cycles. The cycle time will automatically be extended to allow for recovery of correct operating temperatures.

| Model | Rack size mm | Useable Height mm | Dimensions mm W x D x H | Cycle Options | Power kW | Amps Required | Price |
|--------------------|--------------|-------------------|-------------------------------|---------------|----------|---------------------|----------------|
| C2035 WS HR | 500 | 435 | 640 x 745 x 2200 [#] | 3 Cycles | 4.5/6.5 | 20/30 ^{##} | £10,760 |

[#] Height adjustable from 2200 to 2260mm.

^{##} Machines will be supplied for 30 amp supply as standard, if 20 amp required specify at time of order.

|  C Range ancillaries | | | MODEL SUITABILITY | | | | | | | | | | | |
|---|-------------------------|-----------|-------------------|--------------|---------|--------------|--------------|--------------|---------|------|---------|------|----------------|----------|
| | | | C352 / C352D | C402 / C402D | C405 WS | C452 / C452D | C502 / C502D | C512 / C512D | C525 WS | C612 | C615 WS | C652 | C2011 / C2011D | C2035 WS |
| ANCILLARY DETAILS | PART NUMBER | PRICE | | | | | | | | | | | | |
| Water softener-manual Manual regeneration 8 litre | Q900008B | £104.53 | ● | ● | | ● | | | | | | | | |
| Water softener-manual Manual regeneration 12 litre | Q900012B | £123.14 | ● | ● | | ● | ● | ● | ● | | ● | ● | | |
| Water softener-manual Manual regeneration 16 litre | Q900016B | £135.92 | | | | | ● | ● | ● | | ● | ● | | |
| Water softener-manual Manual regeneration 20 litre | Q900020B | £163.17 | | | | | ● | ● | ● | | ● | ● | | |
| Water softener-auto Automatic regeneration – COLD water (5°C to 50°C / 1400 litre capacity)* | Q900100B | £692.89 | ● | ● | | ● | ● | ● | ● | | ● | ● | | |
| Water softener-auto Automatic regeneration – HOT water (10°C to 70°C / 2595 litre capacity)* | Q900105B | £765.02 | ● | ● | | ● | ● | ● | ● | | ● | ● | | |
| Battery operated water softener-auto Removes need for electrical socket (1520 litre capacity)* | Q941311B | £963.98 | ● | ● | | ● | ● | ● | ● | | ● | ● | | |
| Battery operated water softener-auto Removes need for electrical socket (3040 litre capacity)* | Q941312B | £1,309.29 | ● | ● | | ● | ● | ● | ● | | ● | ● | | |
| Pressure set and expansion vessel Increases and regulates water pressure | Q904006B | £473.55 | ● | ● | ● | ● | ● | ● | ● | ● | ● | ● | ● | ● |
| Machine stand-black Black paint finish adjustable machine stand – 520mm tall | Q902100B | £94.29 | ● | ● | ● | ● | ● | ● | | | | | | |
| Additional racks 350 x 350 Open glass/cup rack – plastic | Q902302B | £83.32 | ● | | | | | | | | | | | |
| Additional racks 390 x 390 Open glass/cup rack – plastic | Q902303B | £111.15 | | ● | ● | | | | | | | | | |
| Additional racks 450 x 450 Open glass/cup rack – plastic | Q902300AB | £22.15 | | | | ● | | | | | | | | |
| Additional racks 450 x 450 Useful small plate pegged rack – plastic | Q902301B | £30.08 | | | | ● | | | | | | | | |
| Additional racks 500 x 500 Open glass/cup rack – plastic | Z972001 | £23.84 | | | | | ● | ● | ● | ● | ● | ● | ● | ● |
| Additional racks 500 x 500 Pegged plate rack – plastic | Z972003 | £24.95 | | | | | ● | ● | ● | ● | ● | ● | ● | ● |
| Cutlery rack Eight section cutlery rack insert for 500mm racks | Z972032 | £16.08 | | | | | ● | ● | ● | ● | ● | ● | ● | ● |
| Additional racks 500 x 600 Open glass/cup rack – plastic | Q902016B | £111.63 | | | | | | | ● | ● | ● | | | |
| Additional racks 500 x 600 Plate rack – plastic | Q902017B | £111.63 | | | | | | | ● | ● | ● | | | |
| Additional racks 500 x 600 Tray rack – plastic | Q902018B | £162.24 | | | | | | | ● | ● | ● | | | |
| S/S container insert Capacity 5 x 1/1 gastronorm containers – maximum depth 65mm | MH101491B | £222.00 | | | | | | | ● | ● | ● | | | |
| S/S container insert Capacity 8 x 1/1 gastronorm containers – maximum depth 40mm | MH103454B | £187.84 | | | | | | | ● | ● | ● | | | |
| Dishwasher Starter Pack Consisting of 2 x 5 litres Low Temp, 2 x 5 litres Super Rinse Aid, 1 x 2kg Granular Salt | DISHWASHER STARTER KIT | £76.52 | | | | | | ● | ● | ● | ● | ● | ● | ● |
| Glasswasher Starter Pack Consisting of 2 x 5 litres Premier Glasswash Detergent, 2 x 5 litres Super Rinse Aid, 1 x 2kg Granular Salt | GLASSWASHER STARTER KIT | £76.52 | ● | ● | ● | ● | ● | ● | ● | ● | ● | ● | ● | ● |

* see page 50 for further detail and options.

|  C Range at a glance | | | | | | | | |
|--|------------------|--------------|-----------|----------------|------------|---------------|----------------------|---------|
| Model | Type | Rack Size mm | Breaktank | Water Softener | Drain Pump | Heat Recovery | Available in 3 Phase | Price |
| C352 | Glasswasher | 350 | | | | | | £2,010 |
| C352D | Glasswasher | 350 | | | ● | | | £2,220 |
| C402 | Glasswasher | 390 | | | | | | £2,450 |
| C402D | Glasswasher | 390 | | | ● | | | £2,660 |
| C405 WS | Glasswasher | 390 | | ● | ● | | | £2,970 |
| C452 | Glasswasher | 450 | | | | | | £3,210 |
| C452D | Glasswasher | 450 | | | ● | | | £3,370 |
| C502* | Glasswasher | 500 | | | | | ● | £3,810 |
| C502D | Glasswasher | 500 | | | ● | | ● | £4,060 |
| C512* | Glass/Dishwasher | 500 | ● | | | | ● | £4,070 |
| C512D | Glass/Dishwasher | 500 | ● | | ● | | ● | £4,320 |
| C525 WS | Glass/Dishwasher | 500 | ● | ● | ● | | ● | £4,620 |
| C612 | Tray/Dishwasher | 500 x 600 | ● | | ● | | ● | £5,800 |
| C615 WS | Tray/Dishwasher | 500 x 600 | ● | ● | ● | | ● | £6,320 |
| C652 | Tray/Dishwasher | 500 x 600 | ● | | ● | | ● | £6,530 |
| C2011* | Pass Through | 500 | ● | | | | ● | £6,390 |
| C2011D | Pass Through | 500 | ● | | ● | | ● | £6,680 |
| C2035 WS | Pass Through | 500 | ● | ● | ● | | ● | £7,020 |
| C2035 WS HR | Pass Through | 500 | ● | ● | ● | ● | ● | £10,760 |

* Drain pump cannot be retro fitted.



Warewashing Engineers Appreciation Training Days

Award Winning Training
from **Maidaid**

Our award winning **Technical Appreciation Training** day provides engineers with a comprehensive hands on experience to give them the confidence to safely install, maintain and repair Maidaid warewashing equipment.

Our tailored full day course gives engineers the opportunity to put the knowledge gained into practice when they deal with 'real life' scenarios.

Technical Appreciation Topics Covered:

- ✓ Installation
- ✓ Diagnostics
- ✓ Open Q&A session throughout the day
- ✓ Programming
- ✓ Practical fault finding and programming
- ✓ Operation

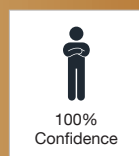

To find out the date of the next Warewashing Engineers Appreciation Training Day or reserve your place please call **0345 130 8070** or email **marketing@maidaid-halcyon.co.uk**



The Engine Shed,
Top Station Road, Brackley,
Northants NN13 7UG

T: 0345 1308070
E: marketing@maidaid-halcyon.co.uk
W: maidaid.co.uk



D Range

Undercounter Glasswashers
Undercounter Glass/Dishwashers
Pass Through Glass/Dishwashers





D Range | undercounter



D502

Scan the QR code to view the D RANGE Undercounter Glasswasher operator training video



- **2 year warranty**
- Four button bright LED display with soft touch controls, twin traffic lights giving instant status updates & operational self-diagnostics
- Alarms menu with hi-level information retrieval
- Improved wash action from quick release parallel wash & rinse arm design
- Improved triple wash tank filtration system
- Drain pump fitted as standard
- Three standard cycle time options with a range of special cycles
- Cycle times can be tailored to site requirements
- Comprehensive automatic self-cleaning at end of service
- Selectable energy saving mode
- Selectable thermostop ensures optimum rinse temperatures
- Fully double skinned minimising both acoustic output and reduced heat-loss
- Patented dual flow wash pump with **soft start** – reducing power consumption whilst retaining wash efficiency
- Full door seal and door ajar facility
- Moulded wash tank for easy cleaning
- Moulded rack guide
- Surface scrap tray filters supplied as standard
- Accurate detergent & rinse aid peristaltic dosing pumps as standard
- Supplied with two open cup/glass racks & cutlery insert



Four button bright LED display with soft touch controls & twin traffic lights giving instant status updates

Technical

- Standard voltage 230V – single phase (can be supplied for 3 phase – **please specify at time of order**)
- Suitable for hot (max 50°C) or cold water supply, typically at 2 to 4 bar dynamic supply pressure, refer to specification sheets for individual requirements
- Wash temperature 60°C (adjustable)
- Rinse temperature 65°C (adjustable)
- Cycle times between 70 & 240 secs, dependent on model

Requires a waste up stand for correct operation.

Restrictive waste connections should be avoided for all installations.

All 500 basket machines supplied 13 amp will come with moulded plug and cable.

Machine configured for 13 amp supply or fitted to cold water supply will not be capable of running repeated short cycles. The cycle time will automatically be extended to allow for recovery of correct operating temperatures.

| Model | Rack size mm | Useable Height mm | Dimensions mm W x D x H | Cycle Options | Power kW | Amps Required | Price |
|-------|--------------|-------------------|------------------------------|---------------|-------------|------------------------|--------|
| D502 | 500 | 260 | 600 x 600 x 710 [#] | 3 Cycles | 2.6/4.5/6.5 | 13/20/30 ^{##} | £4,900 |

[#] Height excludes adjustable feet which will add 10 to 20mm.

^{##} Machines will be supplied for 30 amp supply as standard. If supplied 13 amp machine will come fitted with moulded plug and cable.

20 amp machines will be supplied with original cable and without plug. Standard 13 amp UK 3 pin plugs will be **unsuitable** for cable supplied.

See page 19 for ancillary items.

D Range | undercounter

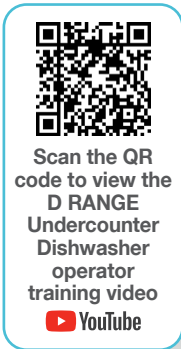

D512



D525 WS

- **2 year warranty**
- Four button bright LED display with soft touch controls, twin traffic lights giving instant status updates & operational self-diagnostics
- Alarms menu with hi-level information retrieval
- Improved wash action from quick release parallel wash & rinse arm design
- Improved triple wash tank filtration system
- D525 WS with **automatic** internal continuous water softener as standard
- Breaktank supplied as standard
- Three standard cycle time options with a range of special cycles
- Cycle times can be tailored to site requirements
- Comprehensive automatic self-cleaning at end of service
- Selectable energy saving mode
- Selectable thermostop ensures optimum rinse temperatures
- Fully double skinned minimising both acoustic output and reduced heat-loss
- Patented dual flow wash pump with **soft start** – reducing power consumption whilst retaining wash efficiency
- Full door seal and door ajar facility
- Moulded wash tank for easy cleaning
- Moulded rack guide
- Surface scrap tray filters supplied as standard
- Accurate detergent & rinse aid peristaltic dosing pumps as standard
- Supplied with one pegged rack, one open cup/glass rack & cutlery insert



Four button bright LED display with soft touch controls & twin traffic lights giving instant status updates

Technical

- Standard voltage 230V – single phase (can be supplied for 3 phase – **please specify at time of order**)
- Suitable for hot (max 50°C) or cold water supply, typically at 2 to 4 bar dynamic supply pressure, refer to specification sheets for individual requirements
- Wash temperature 60°C (adjustable)
- Rinse temperature 82°C (adjustable)
- Cycle times between 70 & 240 secs, dependent on model

Requires a waste up stand for correct operation. Restrictive waste connections should be avoided for all installations.

All 500 basket machines supplied 13 amp will come with moulded plug and cable.

Machine configured for 13 amp supply or fitted to cold water supply will not be capable of running repeated short cycles. The cycle time will automatically be extended to allow for recovery of correct operating temperatures.

| Model | Rack size mm | Useable Height mm | Dimensions mm W x D x H | Cycle Options | Power kW | Amps Required | Price |
|---------|--------------|-------------------|-------------------------|---------------|-------------|---------------|--------|
| D512 | 500 | 365 | 600 x 600 x 810# | 3 Cycles | 2.6/4.5/6.5 | 13/20/30## | £5,090 |
| D525 WS | 500 | 365 | 600 x 630 x 810# | 3 Cycles | 2.6/4.5/6.5 | 13/20/30## | £5,870 |

Height excludes adjustable feet which will add 10 to 20mm.

Machines will be supplied for 30 amp supply as standard. If supplied 13 amp machine will come fitted with moulded plug and cable.

20 amp machines will be supplied with original cable and without plug. Standard 13 amp UK 3 pin plugs will be **unsuitable** for cable supplied.

See page 19 for ancillary items.

D Range | pass through



Scan the QR code to view the D RANGE Pass Through Dishwasher operator training video
 YouTube



D3121
 (shown with tableting, sink and pre-wash spray arm – not included)

D2121
 (shown with tableting – not included)



Four button bright LED display with soft touch controls & twin traffic lights giving instant status updates

- 2 year warranty
- D3121 high powered 3 phase machine for heavy duty use
- Four button bright LED display with soft touch controls, twin traffic lights giving instant status updates & operational self-diagnostics
- Alarms menu with hi-level information retrieval
- Improved wash action from quick release parallel wash & rinse arm design
- Improved triple wash tank filtration system
- Fitted drain pump & breaktank supplied as standard
- Three standard cycle time options with a range of special cycles
- Cycle times can be tailored to site requirements
- Comprehensive automatic self-cleaning at end of service
- Selectable energy saving mode
- Selectable thermostop ensures optimum rinse temperatures
- Fully double skinned body construction with single skinned hood
- Patented dual flow wash pump – reducing power consumption whilst retaining wash efficiency
- Moulded wash tank for easy cleaning
- Surface scrap tray filters supplied as standard
- Accurate detergent & rinse aid peristaltic dosing pumps as standard
- Supplied with one pegged rack, one open cup/glass rack & cutlery insert

Technical

- D3121 3 phase only
- D2121 standard voltage 230V – single phase (can be supplied 3 phase – **please specify at time of order**)
- Suitable for hot (max 50°C) or cold water supply, typically at 2 to 4 bar dynamic supply pressure, refer to specification sheets for individual requirements
- Wash temperature 60°C (adjustable)
- Rinse temperature 82°C (adjustable)
- Cycle times between 70 & 240 secs

Requires a waste up stand for correct operation. Restrictive waste connections should be avoided for all installations.

Machines fitted to cold water supply will not be capable of running repeated short cycles. The cycle time will automatically be extended to allow for recovery of correct operating temperatures.

| Model | Rack size mm | Useable Height mm | Dimensions mm W x D x H | Cycle Options | Power kW | Amps Required | Price |
|--------------|--------------|-------------------|-------------------------------|---------------|----------|---------------------|---------------|
| D2121 | 500 | 440 | 640 x 755 x 1535 [#] | 3 Cycles | 4.7/6.7 | 20/30 ^{##} | £8,180 |
| D3121 | 500 | 440 | 640 x 755 x 1535 [#] | 3 Cycles | 10.2 | 20 ^{###} | £8,830 |

Height adjustable from 1535 to 1595mm (hood closed), 2050 to 2110mm (hood open). Heights include adjustable feet.

D2121 will be supplied for 30amp supply as standard, if 20 amp required specify at time of order.

D3121 will be supplied 3 phase 20amp only.

See page 19 for ancillary items.

|  D Range ancillaries | | | MODEL SUITABILITY | | | | |
|---|------------------------------------|------------------|-------------------|------|---------|-------|-------|
| | | | D502 | D512 | D525 WS | D2121 | D3121 |
| ANCILLARY DETAILS | PART NUMBER | PRICE | | | | | |
| Water softener-manual Manual regeneration 12 litre | Q900012B | £123.14 | ● | ● | | ● | ● |
| Water softener-manual Manual regeneration 16 litre | Q900016B | £135.92 | ● | ● | | ● | ● |
| Water softener-manual Manual regeneration 20 litre | Q900020B | £163.17 | ● | ● | | ● | ● |
| Water softener-auto Automatic regeneration – COLD water (5°C to 50°C / 1400 litre capacity)* | Q900100B | £692.89 | ● | ● | | ● | ● |
| Water softener-auto Automatic regeneration – HOT water (10°C to 70°C / 2595 litre capacity)* | Q900105B | £765.02 | ● | ● | | ● | ● |
| Battery operated water softener-auto Removes need for electrical socket (1520 litre capacity)* | Q941311B | £963.98 | ● | ● | | ● | ● |
| Battery operated water softener-auto Removes need for electrical socket (3040 litre capacity)* | Q941312B | £1,309.29 | ● | ● | | ● | ● |
| Pressure set and expansion vessel Increases and regulates water pressure | Q904006B | £473.55 | ● | ● | ● | ● | ● |
| Machine stand-black Black paint finish adjustable machine stand – 520mm tall | Q902100B | £94.29 | ● | ● | ● | | |
| Additional racks 500 x 500 Open glass/cup rack – plastic | Z972001 | £23.84 | ● | ● | ● | ● | ● |
| Additional racks 500 x 500 Pegged plate rack – plastic | Z972003 | £24.95 | ● | ● | ● | ● | ● |
| Cutlery rack Eight section cutlery rack insert for 500mm racks | Z972032 | £16.08 | ● | ● | ● | ● | ● |
| Dishwasher Starter Pack Consisting of 2 x 5 litres Low Temp, 2 x 5 litres Super Rinse Aid, 1 x 2kg Granular Salt | DISHWASHER STARTER KIT | £76.52 | | ● | ● | ● | ● |
| Glasswasher Starter Pack Consisting of 2 x 5 litres Premier Glasswash Detergent, 2 x 5 litres Super Rinse Aid, 1 x 2kg Granular Salt | GLASSWASHER STARTER KIT | £76.52 | ● | ● | ● | ● | ● |

* see page 50 for further detail and options.

|  D Range at a glance | | | | | | | |
|--|------------------|--------------|-----------|----------------|------------|----------------------|---------------|
| Model | Type | Rack Size mm | Breaktank | Water Softener | Drain Pump | Available in 3 Phase | Price |
| D502 | Glasswasher | 500 | | | ● | ● | £4,900 |
| D512 | Glass/Dishwasher | 500 | ● | | ● | ● | £5,090 |
| D525 WS | Glass/Dishwasher | 500 | ● | ● | ● | ● | £5,870 |
| D2121 | Pass Through | 500 | ● | | ● | ● | £8,180 |
| D3121 | Pass Through | 500 | ● | | ● | ● 3 phase only | £8,830 |



FREE Warewashing Sales Training Day



100%
Confidence



Maximum
Profits

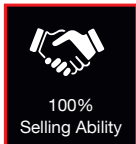

100%
Selling Ability



Training
Certificates



**award
winning
training**

To be able to effectively sell the right machine for the job, it is imperative to appreciate the many features of the entire Maidaid range, and to understand the technology plus the various operating systems and tabling options.



Not to be missed topics include:

- ✓ Specify the right machine for the job
- ✓ How to site survey
- ✓ Problems: How to deal with them and how to avoid them in the first place
- ✓ Breaktanks, booster pumps and softeners
- ✓ Machine power requirements
- ✓ How to give technical support
- ✓ Add value and profit to your order opportunity
- ✓ Testing for water pressure and hardness
- ✓ Dealing effectively with a customer wanting a discount
- ✓ Available eco-benefits – water consumption down to as little as 1.8 litres per basket.



To find out the date of the next Warewashing Sales Training Day or reserve your place please call **0345 130 8070** or email **sales@maidaid-halcyon.co.uk**



EVOLUTION Range

Undercounter
Glass/Dishwashers
Pass Through
Glass/Dishwashers

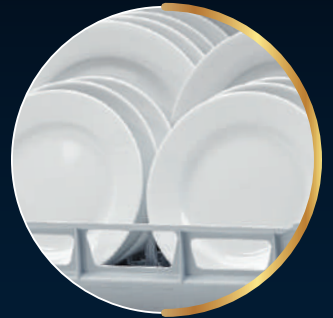

Evolution | undercounter

Scan the QR code
to view the
EVOLUTION RANGE
Undercounter
Glasswasher
operator training
video



EVOLUTION
402 & 425 WS

EVOLUTION
502 & 525 WS



The easy to use soft touch keys complement a large backlit polychromatic LCD display.

Unlike other dishwashers on the market, it is not just a button; the entire screen changes colour according to the operating status of the machine and the current stage of the wash cycle; this makes it easy to read and interpret even from a distance.

RED = in Alarm

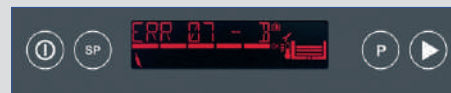

BLUE = in Cycle

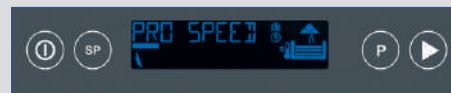

YELLOW = is Heating, but will still function

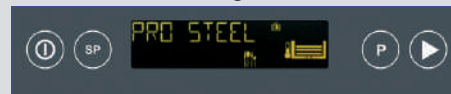

GREEN = Ready to go

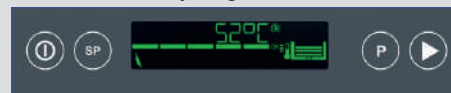

- **2 year warranty**
- Improved wash action from quick release parallel wash & rinse arm design
- Stainless steel scrap tray filters supplied as standard on 502 & 525 WS
- Improved triple wash tank filtration system
- Increased range of water hardness settings on 425 WS & 525 WS
- Four button control fascia with special programmes button, operational self-diagnostics & alarms menu
- Evolution 425 WS & 525 WS with internal **automatic** continuous water softener as standard
- Composite scrap tray filters supplied as standard on the 402 & 425 WS
- Drain pump and breaktank supplied as standard
- Three standard cycle time options with an extensive range of special cycles
- Cycle times can be tailored to site requirements
- Comprehensive automatic self-cleaning at end of service
- Selectable energy saving mode
- Selectable thermostop ensures optimum rinse temperatures
- Fully double skinned minimising both acoustic output and reduced heat-loss
- Patented dual flow wash pump with **soft start** – reducing power consumption whilst retaining wash efficiency
- Full door seal and door ajar facility
- Moulded wash tank for easy cleaning
- Moulded rack guide
- Accurate detergent & rinse aid peristaltic dosing pumps as standard
- Priming and dosing of chemicals enabled from fascia controls
- Supplied with two open cup/glass racks & cutlery insert

Technical

- Standard voltage 230V – single phase (502 & 525 WS can be supplied 3 phase – **please specify at time of order**)
- Suitable for hot (max 50°C) or cold water supply, typically at 2 to 4 bar dynamic supply pressure, refer to specification sheets for individual requirements
- Wash temperature 60°C (adjustable)
- Rinse temperature 402, 425WS & 502 65°C (adjustable)
- Rinse temperature 525WS 82°C (adjustable)
- Cycle times between 90 & 715 secs, including special cycles

Requires a waste up stand for correct operation.

Restrictive waste connections should be avoided for all installations.

Machines supplied 13 amp will come with moulded plug and cable.

Machine configured for 13 amp supply or fitted to cold water supply will not be capable of running repeated short cycles. The cycle time will automatically be extended to allow for recovery of correct operating temperatures.

| Model | Rack size mm | Useable Height mm | Dimensions mm W x D x H | Cycle Options | Power kW | Amps Required | Price |
|-------------------------|--------------|-------------------|------------------------------|---------------|-------------|------------------------|---------------|
| Evolution 402 | 400 | 295 | 465 x 560 x 690 [†] | 3 Cycles | 2.9 | 13 | £4,630 |
| Evolution 425 WS | 400 | 295 | 465 x 560 x 690 [†] | 3 Cycles | 2.9 | 13 | £5,240 |
| Evolution 502 | 500 | 265 | 600 x 600 x 710 [#] | 3 Cycles | 2.6/4.5/6.5 | 13/20/30 ^{##} | £5,230 |
| Evolution 525 WS | 500 | 265 | 600 x 630 x 710 [#] | 3 Cycles | 2.6/4.5/6.5 | 13/20/30 ^{##} | £5,820 |

[†] Height excludes adjustable feet which will add 5 to 15mm. [#] Height excludes adjustable feet which will add 10 to 20mm.

^{##} Machines will be supplied for 30 amp supply as standard. If supplied 13 amp machine will come fitted with moulded plug and cable. 20 amp machines will be supplied with original cable and without plug – please specify at time of order. Standard 13 amp UK 3 pin plugs will be **unsuitable** for cable supplied.

See page 27 for ancillary items.

Evolution | undercounter

Scan the QR code to view the **EVOLUTION RANGE Undercounter Dishwasher operator training video**



YouTube



EVOLUTION 512

EVOLUTION 535 WS



The easy to use soft touch keys complement a large backlit polychromatic LCD display.

Unlike other dishwashers on the market, it is not just a button; the entire screen changes colour according to the operating status of the machine and the current stage of the wash cycle; this makes it easy to read and interpret even from a distance.

RED = in Alarm

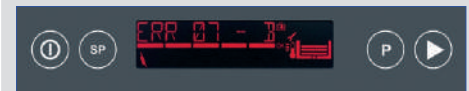

BLUE = in Cycle

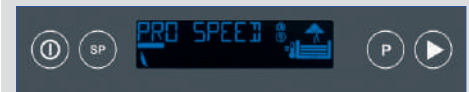

YELLOW = is Heating, but will still function



GREEN = Ready to go

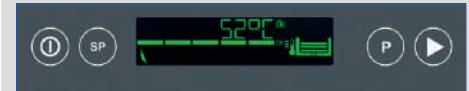

- **2 year warranty**
- Improved wash action from quick release parallel wash & rinse arm design
- Stainless steel scrap tray filters supplied as standard
- Improved triple wash tank filtration system
- Increased range of water hardness settings on 535 WS
- Four button control fascia with special programmes button, operational self-diagnostics & alarms menu
- Evolution 535 WS with internal **automatic** continuous water softener as standard
- Drain pump and breaktank supplied as standard
- Three standard cycle time options with an extensive range of special cycles
- Cycle times can be tailored to site requirements
- Comprehensive automatic self-cleaning at end of service
- Selectable energy saving mode
- Selectable thermostop ensures optimum rinse temperatures
- Fully double skinned minimising both acoustic output and reduced heat-loss
- Patented dual flow wash pump with **soft start** - reducing power consumption whilst retaining wash efficiency
- Full door seal and door ajar facility
- Moulded wash tank for easy cleaning
- Moulded rack guide
- Accurate detergent & rinse aid peristaltic dosing pumps as standard
- Priming and dosing of chemicals enabled from fascia controls
- Supplied with one pegged rack, one open cup/glass rack & cutlery insert

Technical

- Standard voltage 230V – single phase (can be supplied for 3 phase – **please specify at time of order**)
- Suitable for hot (max 50°C) or cold water supply, typically at 2 to 4 bar dynamic supply pressure, refer to specification sheets for individual requirements
- Wash temperature 60°C (adjustable)
- Rinse temperature 82°C (adjustable)
- Cycle times between 90 & 715 secs, including special cycles

Requires a waste up stand for correct operation.

Restrictive waste connections should be avoided for all installations.

All 500 basket machines supplied 13 amp will come with moulded plug and cable.

Machine configured for 13 amp supply or fitted to cold water supply will not be capable of running repeated short cycles. The cycle time will automatically be extended to allow for recovery of correct operating temperatures.

| Model | Rack size mm | Useable Height mm | Dimensions mm W x D x H | Cycle Options | Power kW | Amps Required | Price |
|-------------------------|--------------|-------------------|------------------------------|---------------|-------------|------------------------|---------------|
| Evolution 512 | 500 | 365 | 600 x 600 x 810 [#] | 3 Cycles | 2.6/4.5/6.5 | 13/20/30 ^{##} | £5,870 |
| Evolution 535 WS | 500 | 365 | 600 x 630 x 810 [#] | 3 Cycles | 2.6/4.5/6.5 | 13/20/30 ^{##} | £6,440 |

Height excludes adjustable feet which will add 10 to 20mm.

Machines will be supplied for 30 amp supply as standard. If supplied 13 amp machine will come fitted with moulded plug and cable.

20 amp machines will be supplied with original cable and without plug – please specify at time of order.

Standard 13 amp UK 3 pin plugs will be **unsuitable** for cable supplied.

It is strongly recommended that 500mm machines are installed on hot water fill (max 50°C) for optimum performance.

See page 27 for ancillary items.

Evolution | pass through

Scan the QR code
to view the
EVOLUTION RANGE
Pass Through
Dishwasher
operator training
video



YouTube

EVOLUTION
2121, 2135 WS
& 3135 WS
(shown with tabling –
not included)

EVOLUTION 2160
(shown with tabling –
not included)

- **2 year warranty**
- Evolution 2160 3 phase 500 x 600 rack machine, with quick release triple wash & rinse arm design, powerful wash pump & boiler element for heavy duty use
- Evolution 3135 WS 3 phase 500 x 500 rack machine with continuous internal **automatic** water softener and powerful boiler element allowing for rapid recovery
- Four button control fascia with special programmes button, operational self-diagnostics & alarms menu
- Improved wash action from quick release parallel wash & rinse arm design
- Stainless steel scrap tray filters supplied as standard
- Improved triple wash tank filtration system
- Increased range of water hardness settings on 2135 WS & 3135 WS
- Evolution 2135 WS & 3135 WS with internal **automatic** continuous water softener as standard
- Drain pump and breaktank supplied as standard
- Three standard cycle time options with an extensive range of special cycles
- Cycle times can be tailored to site requirements
- Comprehensive automatic self-cleaning at end of service
- Selectable energy saving mode

- Selectable thermostop ensures optimum rinse temperatures
- Fully double skinned body & hood construction minimising both acoustic output and reduced heat-loss
- Easy lift super glide hood system
- Patented dual flow wash pump – reducing power consumption whilst retaining wash efficiency
- Moulded wash tank for easy cleaning
- Accurate detergent & rinse aid peristaltic dosing pumps as standard
- Supplied with one pegged rack, one open cup/glass rack & cutlery insert

Technical

- 2121 & 2135 WS standard voltage 230V – single phase (can be supplied for 3 phase – **please specify at time of order**)
- Evolution 2160 and 3135 WS only available in 3 phase
- Evolution 2160 only suitable for in-line tabling arrangement
- Suitable for hot (max 50°C) or cold water supply, typically at 2 to 4 bar dynamic supply pressure, refer to specification sheets for individual requirements
- Wash temperature 60°C (adjustable)
- Rinse temperature 82°C (adjustable)
- Cycle times between 70 & 715 secs, including special cycles

The easy to use soft touch keys complement a large backlit polychromatic LCD display.

Unlike other dishwashers on the market, it is not just a button; the entire screen changes colour according to the operating status of the machine and the current stage of the wash cycle; this makes it easy to read and interpret even from a distance.

RED = in Alarm

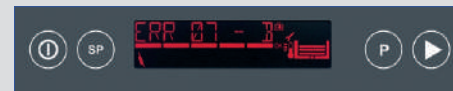

BLUE = in Cycle

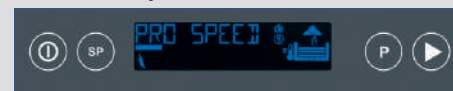

YELLOW = is Heating, but will still function



GREEN = Ready to go

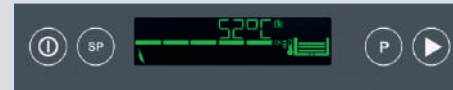

Requires a waste up stand for correct operation.
Restrictive waste connections should be avoided for all installations.

Machines fitted to cold water supply will not be capable of running repeated short cycles. The cycle time will automatically be extended to allow for recovery of correct operating temperatures.

| Model | Rack size mm | Useable Height mm | Dimensions mm W x D x H | Cycle Options | Power kW | Amps Required | Price |
|--------------------------|--------------|-------------------|-------------------------------|---------------|----------|---------------------|----------------|
| Evolution 2121 | 500 | 440 | 640 x 755 x 1535 [#] | 3 Cycles | 4.7/6.7 | 20/30 ^{##} | £9,340 |
| Evolution 2135 WS | 500 | 440 | 640 x 755 x 1535 [#] | 3 Cycles | 4.7/6.7 | 20/30 ^{##} | £9,890 |
| Evolution 2160 | 500 x 600 | 440 | 700 x 755 x 1535 [#] | 3 Cycles | 11.0 | 25 (3 phase only) | £11,610 |
| Evolution 3135 WS | 500 x 500 | 440 | 640 x 755 x 1535 [#] | 3 Cycles | 10.2 | 20 (3 phase only) | £10,300 |

[#] Height adjustable from 1535 to 1595 (hood closed), 2050 to 2110mm (hood open). Heights include adjustable feet.

^{##} Machines will be supplied for 30 amp supply as standard, if 20 amp required specify at time of order.

It is strongly recommended that 500mm machines are installed on hot water fill (max 50°C) for optimum performance.

See page 27 for ancillary items.

Evolution | pass through + heat recovery



Scan the QR code to view the **EVOLUTION RANGE** Pass Through Dishwasher operator training video

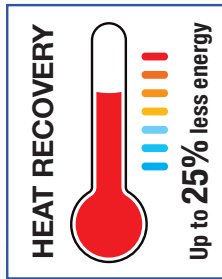

EVOLUTION 2135 WS HR
(shown with tabling – not included)

EVOLUTION 2160 WS HR
(shown with tabling – not included)

The easy to use soft touch keys complement a large backlit polychromatic LCD display.

Unlike other dishwashers on the market, it is not just a button; the entire screen changes colour according to the operating status of the machine and the current stage of the wash cycle; this makes it easy to read and interpret even from a distance.

RED = in Alarm

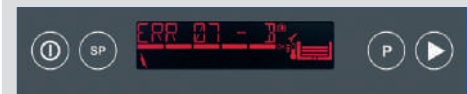

BLUE = in Cycle

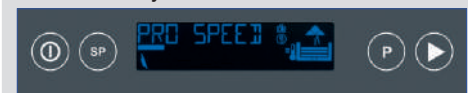

YELLOW = is Heating, but will still function



GREEN = Ready to go

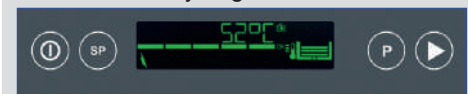

- Wash temperature 60°C (adjustable)
- Rinse temperature 82°C (adjustable)
- Cycle times between 70 & 240 secs

Requires a waste up stand for correct operation. Restrictive waste connections should be avoided for all installations.

Machines fitted to cold water supply will not be capable of running repeated short cycles. The cycle time will automatically be extended to allow for recovery of correct operating temperatures.

* Evolution 2160 WS HR 3 phase 25 amp only. Only suitable for inline tabling arrangement.

- 2 year warranty
- **HEAT RECOVERY** offers up to 25% less power required to heat rinse water
- HR module supplied separately with simple bolt on instructions
- Reduces need for extraction hood and improves working environment
- Evolution 2160 WS HR 3 phase 500 x 600 rack machine with heat recovery, quick release triple wash and rinse arm design, powerful wash pump and boiler element for heavy duty use
- Evolution 2135 WS HR with heat recovery, drain pump, breaktank & internal **automatic** continuous water softener with increased range of water hardness settings as standard
- Four button control fascia with special programmes button, operational self-diagnostics & alarms menu
- Improved wash action from quick release parallel wash & rinse arm design
- Stainless steel scrap tray filters supplied as standard
- Improved triple wash tank filtration system
- Three standard cycle time options with an extensive range of special cycles
- Cycle times can be tailored to site requirements

- Comprehensive automatic self-cleaning at end of service
- Selectable energy saving mode
- Selectable thermostop ensures optimum rinse temperatures
- Fully double skinned body & hood construction minimising both acoustic output and reduced heat-loss
- Easy lift super glide hood system
- Patented dual flow wash pump – reducing power consumption whilst retaining wash efficiency
- Moulded wash tank for easy cleaning
- Accurate detergent & rinse aid peristaltic dosing pumps as standard
- Supplied with one pegged rack, one open cup/glass rack & cutlery insert

Technical

- Evolution 2135 WS HR standard voltage 230V – single phase (can be supplied for 3 phase – **please specify at time of order**)
 - Evolution 2160 WS HR supplied as 3 phase only
 - Suitable for cold water supply only, typically at 2 to 4 bar dynamic supply pressure, refer to specification sheets for individual requirements.
- Cannot be used with hot water supply.**

| Model | Rack size mm | Useable Height mm | Dimensions mm W x D x H | Cycle Options | Power kW | Amps Required | Price |
|------------------------------|--------------|-------------------|-------------------------|---------------|----------|-------------------|----------------|
| Evolution 2160 WS HR* | 500 x 600 | 440 | 700 x 755 x 2235# | 3 Cycles | 11.0 | 25 (3 phase only) | £15,650 |
| Evolution 2135 WS HR | 500 | 440 | 640 x 755 x 2235# | 3 Cycles | 4.7/6.7 | 20/30## | £14,930 |

Height adjustable from 2235 to 2295mm.

Machines will be supplied for 30 amp supply as standard, if 20 amp required specify at time of order.

Evolution | dishwashers with power consumption control

The easy to use soft touch keys complement a large backlit polychromatic LCD display.

Unlike other dishwashers on the market, it is not just a button; the entire screen changes colour according to the operating status of the machine and the current stage of the wash cycle; this makes it easy to read and interpret even from a distance.

RED = in Alarm



BLUE = in Cycle

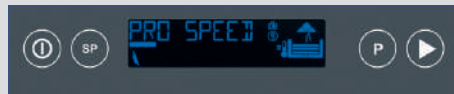

YELLOW = is Heating, but will still function



GREEN = Ready to go

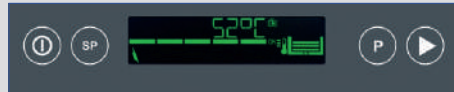

EVOLUTION 2121 COP
(base machine specifications as per Evolution 2121 on page 24)



Scan the QR code to view the EVOLUTION RANGE Undercounter Dishwasher operator training video



YouTube

Scan the QR code to view the EVOLUTION RANGE Pass Through Dishwasher operator training video



YouTube

EVOLUTION 512 COP

(base machine specifications as per Evolution 512 on page 23)



Why choose a Evolution COP (Cut Off Power) dishwasher?

Management of the electrical power consumption of appliances is a daily concern. Ovens, dishwashers, mixers, refrigerators and all other electrical loads, if all used simultaneously, can cause overload of the electrical system and trip the main circuit breaker, thereby bringing work to a halt.

The market offers a wide range of devices to control power usage, with solutions to meet all requirements, but all these automatic devices must be interfaced with the appliances they control without causing any malfunction, so that when power is restored all the appliances return to normal operation.

Maidaid Evolution COP dishwashers are designed to be controlled remotely from electronic control panels that optimise management of the power consumed by the washing system and intervene before an overload occurs, disconnecting appliances according to their priority, thereby ensuring continuity of service.

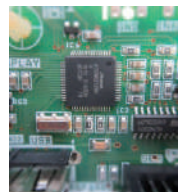

| Model | Rack size mm | Useable Height mm | Dimensions mm W x D x H | Cycle Options | Power kW | Amps Required | Price |
|--------------------|--------------|-------------------|-------------------------------|---------------|-------------|------------------------|--------|
| Evolution 512 COP | 500 | 365 | 600 x 600 x 810 [#] | 3 Cycles | 2.6/4.5/6.5 | 13/20/30 ^{##} | £6,140 |
| Evolution 2121 COP | 500 | 440 | 640 x 755 x 1535 [†] | 3 Cycles | 4.7/6.7 | 20/30 ^{††} | £9,620 |

[#] Height excludes adjustable feet which will add 10 to 20mm.

^{##} Machines will be supplied for 30 amp supply as standard. If supplied 13 amp machine will come fitted with moulded plug and cable. 20 amp machines will be supplied with original cable and without plug – please specify at time of order. Standard 13 amp UK 3 pin plugs will be **unsuitable** for cable supplied. It is strongly recommended that 500mm machines are installed on hot water fill (max 50°C) for optimum performance.

[†] Height adjustable from 1535 to 1595 (hood closed), 2050 to 2110mm (hood open). Heights include adjustable feet.

^{††} Machines will be supplied for 30 amp supply as standard, if 20 amp required specify at time of order. It is strongly recommended that 500mm machines are installed on hot water fill (max 50°C) for optimum performance.

See page 27 for ancillary items.

|  Evolution ancillaries | | | MODEL SUITABILITY | | | | | | | | | | |
|---|----------------------------|-----------|-------------------|------------------|---------------|------------------|-------------------------|------------------|---------------------------|-------------------|----------------|-------------------|----------------------|
| | | | EVOLUTION 402 | EVOLUTION 425 WS | EVOLUTION 502 | EVOLUTION 525 WS | EVOLUTION 512 / 512 COP | EVOLUTION 535 WS | EVOLUTION 2121 / 2121 COP | EVOLUTION 2135 WS | EVOLUTION 2160 | EVOLUTION 3135 WS | EVOLUTION 2135 WS HR |
| ANCILLARY DETAILS | PART NUMBER | PRICE | | | | | | | | | | | |
| Water softener-manual Manual regeneration 8 litre | Q900008B | £104.53 | ● | | | | | | | | | | |
| Water softener-manual Manual regeneration 12 litre | Q900012B | £123.14 | ● | | ● | | ● | | ● | | ● | | ● |
| Water softener-manual Manual regeneration 16 litre | Q900016B | £135.92 | | | ● | | ● | | ● | | ● | | ● |
| Water softener-manual Manual regeneration 20 litre | Q900020B | £163.17 | | | ● | | ● | | ● | | ● | | ● |
| Water softener-auto Automatic regeneration – COLD water (5°C to 50°C / 1400 litre capacity)* | Q900100B | £692.89 | ● | | ● | | ● | | ● | | ● | | ● |
| Water softener-auto Automatic regeneration – HOT water (10°C to 70°C / 2595 litre capacity)* | Q900105B | £765.02 | ● | | ● | | ● | | ● | | ● | | ● |
| Battery operated water softener-auto Removes need for electrical socket (1520 litre capacity)* | Q941311B | £963.98 | ● | | ● | | ● | | ● | | ● | | ● |
| Battery operated water softener-auto Removes need for electrical socket (3040 litre capacity)* | Q941312B | £1,309.29 | ● | | ● | | ● | | ● | | ● | | ● |
| Pressure set and expansion vessel Increases and regulates water pressure | Q904006B | £473.55 | ● | ● | ● | ● | ● | ● | ● | ● | ● | ● | ● |
| Machine stand-black Black paint finish adjustable machine stand – 520mm tall | Q902100B | £94.29 | ● | ● | ● | ● | ● | ● | | | | | |
| Additional racks 400 x 400 Open glass/cup rack – plastic | Q902325B | £40.65 | ● | ● | | | | | | | | | |
| Additional racks 500 x 500 Open glass/cup rack – plastic | Z972001 | £23.84 | | | ● | ● | ● | ● | ● | ● | ● | ● | ● |
| Additional racks 500 x 500 Pegged plate rack – plastic | Z972003 | £24.95 | | | ● | ● | ● | ● | ● | ● | ● | ● | ● |
| Cutlery rack Eight section cutlery rack insert for 500mm racks | Z972032 | £16.08 | | | ● | ● | ● | ● | ● | ● | ● | ● | ● |
| Additional racks 500 x 600 Open glass/cup rack – plastic | Q902016B | £111.63 | | | | | | | | ● | | | ● |
| Additional racks 500 x 600 Plate rack – plastic | Q902017B | £111.63 | | | | | | | | ● | | | ● |
| Additional racks 500 x 600 Tray rack – plastic | Q902018B | £162.24 | | | | | | | | ● | | | ● |
| Dishwasher Starter Pack Consisting of 2 x 5 litres Low Temp, 2 x 5 litres Super Rinse Aid, 1 x 2kg Granular Salt | DISHWASHER STARTER KIT | £76.52 | | | | ● | ● | ● | ● | ● | ● | ● | ● |
| Glasswasher Starter Pack Consisting of 2 x 5 litres Premier Glasswash Detergent, 2 x 5 litres Super Rinse Aid, 1 x 2kg Granular Salt | GLASSWASHER STARTER KIT | £76.52 | ● | ● | ● | ● | ● | ● | ● | ● | ● | ● | ● |

* see page 50 for further detail and options.

|  | | Evolution at a glance | | | | | | | | |
|---|------------------|-----------------------|-----------|----------------|------------|---------------|----------------------|---------|--|--|
| Model | Type | Rack Size mm | Breaktank | Water Softener | Drain Pump | Heat Recovery | Available in 3 Phase | Price | | |
| Evolution 402 | Glasswasher | 400 | ● | | ● | | | £4,630 | | |
| Evolution 425 WS | Glasswasher | 400 | ● | ● | ● | | | £5,240 | | |
| Evolution 502 | Glass/Dishwasher | 500 | ● | | ● | | ● | £5,230 | | |
| Evolution 525 WS | Glass/Dishwasher | 500 | ● | ● | ● | | ● | £5,820 | | |
| Evolution 512 | Glass/Dishwasher | 500 | ● | | ● | | ● | £5,870 | | |
| Evolution 512 COP | Glass/Dishwasher | 500 | ● | | ● | | ● | £6,140 | | |
| Evolution 535 WS | Glass/Dishwasher | 500 | ● | ● | ● | | ● | £6,440 | | |
| Evolution 2121 | Pass Through | 500 | ● | | ● | | ● | £9,340 | | |
| Evolution 2121 COP | Pass Through | 500 | ● | | ● | | ● | £9,620 | | |
| Evolution 2135 WS | Pass Through | 500 | ● | ● | ● | | ● | £9,890 | | |
| Evolution 2160 | Pass Through | 500 x 600 | ● | | ● | | ● 3 phase only | £11,610 | | |
| Evolution 3135 WS | Pass Through | 500 | ● | ● | ● | | ● 3 phase only | £10,300 | | |
| Evolution 2135 WS HR | Pass Through | 500 | ● | ● | ● | ● | ● | £14,930 | | |
| Evolution 2160 WS HR | Pass Through | 500 x 600 | ● | | ● | ● | ● 3 phase only | £15,650 | | |

Have you seen Maidaid's YouTube Channel?



Scan the QR code to view our **Maidaid Evolution Range pass through operator's training video** where you'll learn how to get the most out of your machine, including:



- ✓ Operation
- ✓ Special Programs
- ✓ Washing cycle
- ✓ Temperature display
- ✓ Drain cycle
- ✓ Salting



Check out & subscribe to our channel:
www.youtube.com/@maidaidhalcyon



Sales enquiries:

sales@maidaid-halcyon.co.uk

0345 130 8070

maidaid.co.uk



C, D & EVOLUTION Ranges

Tabling / Scrap Bin / Spray Arms





C, D & Evolution | tabling

Stainless steel scrap bin
c/w castors and lid



704002

£400

Closed end table c/w undershelf.
700mm long, 615mm deep



717000

£410

Closed end table c/w splashback and
undershelf. 700mm long. (Right hand
as illustrated)



80201 (Left hand)

£530

80200 (Right hand)

£530

Closed end table c/w splashback and
undershelf. 1200mm long. (Right hand
as illustrated)



80203 (Left hand)

£740

80204 (Right hand)

£740

Closed end table c/w splashback,
undershelf and sink. 1200mm long.
(Right hand as illustrated)



80205 (Left hand)

£1,170

80206 (Right hand)

£1,170

Closed end table c/w splashback, short
undershelf, sink and scrap hole. 1200mm
long supplied with rubber scrap hole
protection ring. (Right hand as illustrated)



80207 (Left hand)

£1,250

80208 (Right hand)

£1,250

- All tabling is suitable for 500 x 500mm racks
- Supplied flat packed for easy assembly
- All legs supplied with height adjustable feet
- Tables including sinks have **single** ¾" hole for **monoblock** spray arm and 1½" waste
- All sinks are 500mm wide x 400mm front to back x 250mm deep
- All tables with splashback are 745mm deep

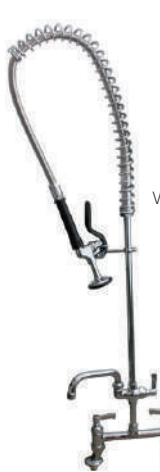
| Item | Description | Part No. | Price | | |
|--------------------------------|---|----------------|----------------|---|--|
| Pre-wash Spray Arms | Pre-wash spray arm: Monoblock spray arm – hot & cold | Z600100 | £283.73 |  | Pre-wash spray arm: Monoblock spray arm – hot & cold water feed with stem tap |
| | Pre-wash spray arm: Monoblock spray arm – hot & cold with stem tap | Z600105 | £532.79 | | |
| | Pre-wash spray arm: Twin pillar spray arm – hot & cold | Z600200 | £289.36 |  | Pre-wash spray arm: Twin pillar spray arm – hot & cold water feed with stem tap |
| | Pre-wash spray arm: Twin pillar spray arm – hot & cold with stem tap | Z600205 | £431.60 | | |



Warewashing Accessories

Baskets, Stands &
Chemical Supplies



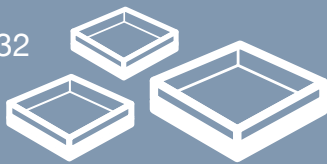







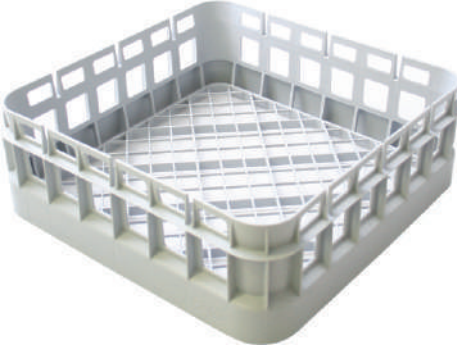



baskets

C, D, Evolution | baskets

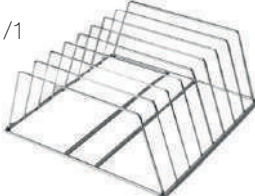
ANCILLARY PRICES are correct at the point of print, but may vary, please contact our sales team for up to date pricing

| | | |
|--|---|--|
| <p>Open plastic rack</p>  | <p>Q902302B £83.32 350 x 350mm – Capable of holding 10 pint glasses</p> <p>Q902303B £111.15 390 x 390mm – Capable of holding 16 pint glasses</p> <p>Q902325B £40.65 400 x 400mm – Capable of holding 16 pint glasses</p> <p>Q902300AB £22.15 450 x 450mm – Capable of holding 20 pint glasses</p> | <p>Plastic pegged plate rack</p>  <p>Q902301B 450 x 450mm Capable of holding 12 x 10" plates</p> <p>£30.08</p> |
| <p>Open plastic rack</p>  <p>Z972001 500 x 500mm Capable of holding 25 pint glasses</p> <p>£23.84</p> | <p>Open plastic rack – close meshed base for cutlery</p>  <p>Z972002 500 x 500mm</p> <p>£23.84</p> | <p>Plastic pegged plate rack</p>  <p>Z972003 500 x 500mm Capable of holding 18 x 10" plates</p> <p>£24.95</p> |
| <p>Plastic pegged tray rack 500 x 500 baskets</p>  <p>Z972030 500 x 500mm Capable of holding 7 trays</p> <p>£24.95</p> | <p>Open glass/cup rack – plastic</p>  <p>Q902016B 500 x 600mm Capable of holding 32 pint glasses</p> <p>£111.63</p> | <p>Plate rack – plastic / Tray rack – plastic</p>  <p>Q902017B (plate rack) 500 x 600mm – Capable of holding 22 x 12" plates</p> <p>£111.63</p> <p>Q902018B (tray rack) 500 x 600mm – Capable of holding 10 trays 53 x 37cm</p> <p>£162.24</p> |
| <p>S/S container inserts</p>  <p>MH101491B Capacity 5 x 1/1 gastronorm containers – maximum depth 65mm</p> <p>£222.00</p> <p>MH103454B Capacity 8 x 1/1 gastronorm containers – maximum depth 40mm</p>  <p>£187.84</p> | <p>Drip tray</p>  <p>Q902200B 375mm square £34.80 Q902201B 425mm square £40.32 Q902202B 470mm square £41.45 Q902203B 520mm square £42.86</p> | <p>Cutlery baskets</p>  <p>Plastic square cutlery basket Z976016 £2.20</p> <p>Plastic round cutlery basket Z976011 £1.43</p> <p>Plastic 8 compartment cutlery basket – fits inside open 500 x 500mm racks Z972032 £16.08</p> |

ANCILLARY PRICES are correct at the point of print, but may vary, please contact our sales team for up to date pricing

maidaid® basket grids

Our **basket grids** are ideally suited for establishments using lightweight plastic washwear.



Image shows
x1 Open Plastic Basket (Z972001 – List Price £23.84)
x2 Open Extenders and a Grid (each item sold separately)

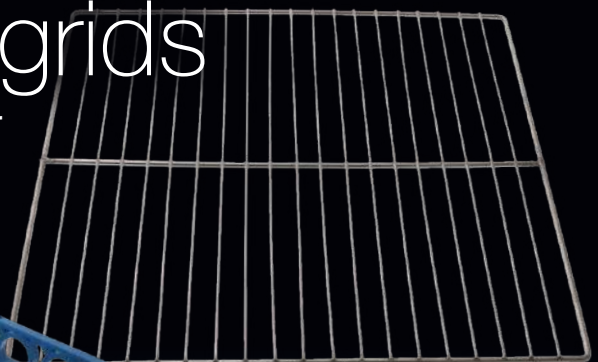

Q402529B List Price **£29.71**

Grid prevents lightweight items from flipping over and collecting water during the wash cycle ensuring they are cleaned correctly ready for re use.

Compatible with 500 x 500mm open glass/cup basket.

Q902324B List Price **£18.34**

Add open extenders to cater for the tallest items in the basket. Each extender adds 40mm to total height.

Universal machine stand – black finish



Q902100B

Depth and width adjustable from 390 to 620mm. Maximum height 520mm, legs can be cut to reduce height. Adjustable feet for leveling

£94.29

maidaid®

Where **extraordinary** comes as **standard**



- Large stock holdings
- Next day delivery
- Award winning technical support
- Finance plans
- Supporting the industry for 50 years
- Nationwide service coverage

maidaid®

WE'RE HERE TO SUPPORT YOU

0345 130 8070

maidaid.co.uk

ANCILLARY PRICES are correct at the point of print, but may vary, please contact our sales team for up to date pricing



DISHWASHER STARTER PACK

Product Code: **DISHWASHER STARTER KIT**

Price: **£76.52**

Consisting of: **2 x 5 litres Low Temp,**
2 x 5 litres Super Rinse Aid, 1 x 2kg Granular Salt

GLASSWASHER STARTER PACK

Product Code: **GLASSWASHER STARTER KIT**

Price: **£76.52**

Consisting of: **2 x 5 litres Premier Glasswash Detergent,**
2 x 5 litres Super Rinse Aid, 1 x 2kg Granular Salt

| Key | Item | Product Code | Packed | Pack Price £ | List Price for 5 litres £ |
|-----|--|--------------|--------------|--------------|---------------------------|
| 1 | Maidaid® Premier Dishwash Detergent | Q902404B | 2 x 5 litres | £45.40 | £22.70 |
| 2 | Maidaid® Low-Temp Glasswasher and Dishwasher Detergent | Q902410B | 2 x 5 litres | £34.88 | £17.44 |
| 3 | Maidaid® Glasswash Detergent | Q902401B | 2 x 5 litres | £30.28 | £15.14 |
| 4 | Maidaid® Super Rinse Aid | Q902407B | 2 x 5 litres | £33.88 | £16.94 |
| 5 | Maidaid® Glass Renovator | Q902402B | 2 x 5 litres | £66.34 | £33.17 |



Rack and Flight Machines

Minirack Glass/Dishwashers
RX Rack Conveyors
QX Flight Machines

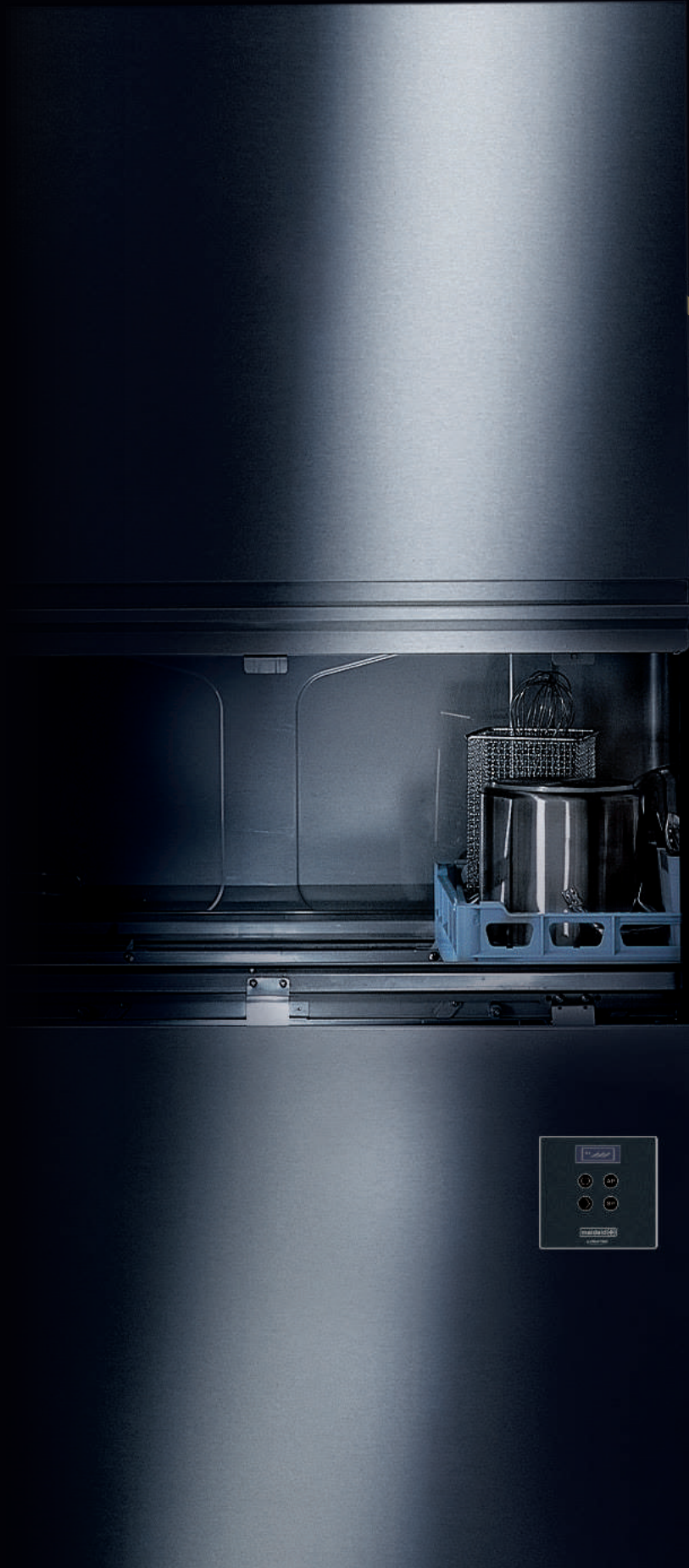

Minirack

EVOLUTION RANGE



R3010 & R3020
Single tank models
(Illustration shown with
tabling – not included)



R3030
Dual tank model
(Illustration shown
with dryer, tabling
and exit splash
guard – not included)

- **1 year warranty**
- Dryer module now available in 6 or 9kW
- Market leading rack machines, a proven design
- Capacity increased to 60 to 270 racks per hour, dependent on model
- Multiple module arrangement options including dryers, heat recovery and steam condenser
- Designed to minimise running costs
- Wash and rinse economisers as standard
- **As little as 1.2 litres of water used per rack**
- Water consumption up to 35% less per rack than a pass through model
- It is strongly recommended that any exit tabling is fitted with rollers to minimise load on rack drive motor and gearbox
- Can be ordered to run left to right or right to left
- **All models use standard 500mm racks with clearance height increased to 430mm**
- Internal design aids daily cleaning
- Full width doors for maximum access
- Breaktank fitted as standard
- Scrap tray to prevent solids fouling wash water
- Supplied as gravity drain only
- Minirack's are not supplied with chemical dosing as standard
- Extraction is required above machines even if fitted with a heat recovery unit

Technical

- All models 3 phase and neutral
- Suitable for hot (max 50°C) or cold water supply at 1.5 to 4 bar, dynamic supply pressure

| Model | Detail | Racks Per Hour | Dimensions mm W x D x H | Power kW (For-parallel heating) | Price |
|----------------------------|---|-----------------------------------|----------------------------|------------------------------------|----------------------|
| R3010[#] | Hot fill | 60 – 120 | 1150 x 770 x 1615 ± 30 | 22.0 | £18,910 |
| R3010C[#] | Cold fill | 60 – 120 | 1150 x 770 x 1615 ± 30 | 28.5 | £19,420 |
| R3020[#] | Hot fill | 60 – 120 – 160 + 80 glass cycle | 1150 x 770 x 1615 ± 30 | 23.2 | £21,910 |
| R3020C[#] | Cold fill | 60 – 120 – 160 + 80 glass cycle | 1150 x 770 x 1615 ± 30 | 34.7 | £22,420 |
| R3030[#] | Hot fill | 110 – 200 – 270 + 135 glass cycle | 1970 x 770 x 1615 ± 30 | 30.2 | £32,890 |
| R3030C[#] | Cold fill | 110 – 200 – 270 + 135 glass cycle | 1970 x 770 x 1615 ± 30 | 45.7 | £33,390 |
| R3-Dose | Optional internally fitted peristaltic detergent and rinse aid dosing pumps | | | | £720 |
| MH101232 / MH101233 | Handed wing splash guard (supplied as part of exit tabling, see page 38). Handing depends on running direction | | | | £94.60 (each) |

Minirack Evolution models.

Models have improved capacity, greater energy efficiency and reduced water consumption. A true evolution in design, taking the best and improving on it!

Minirack

EVOLUTION RANGE



ANCILLARY PRICES are correct at the point of print, but may vary, please contact our sales team for up to date pricing

Minirack R3010 & R3020 – Single Tank Rack Conveyor

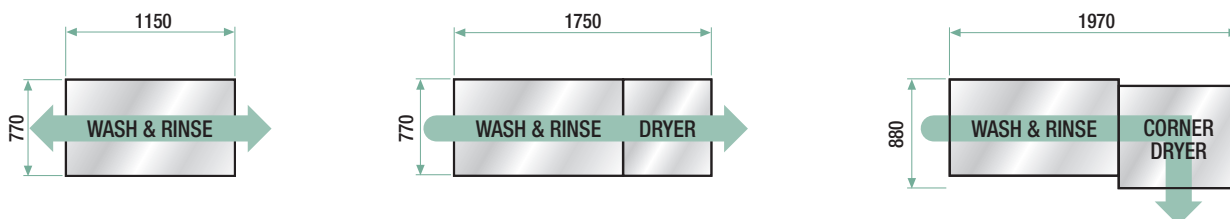

Minirack R3030 – Dual Tank Rack Conveyor

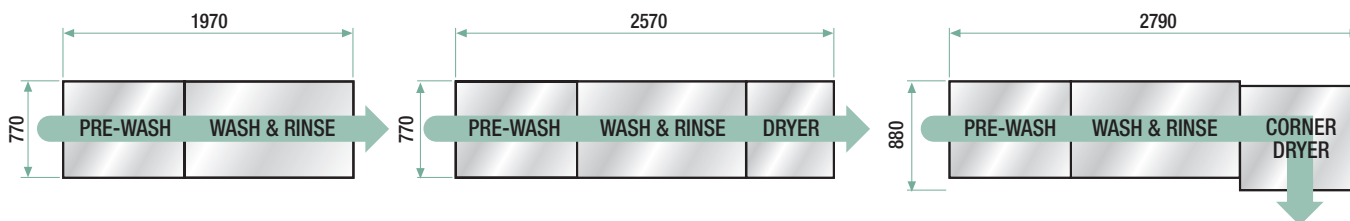

Minirack R3030 – Dual Tank Rack Conveyor (corner pre-wash)

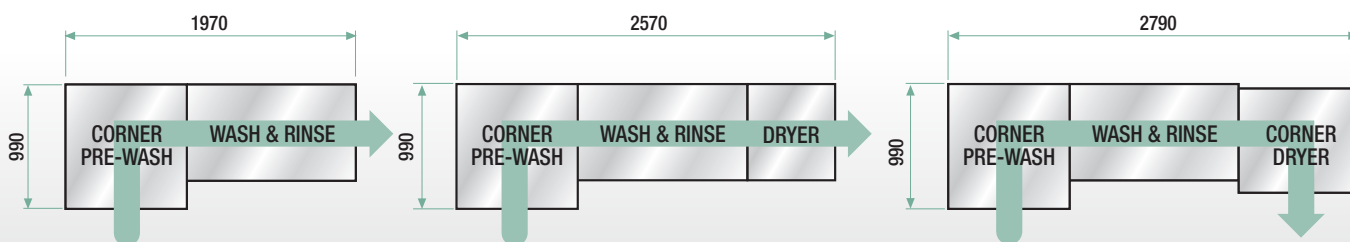

Indicates direction of operation (dirty to clean). All Minirack Evolution models can be ordered running in either direction but must be specified at time of order. Only R3010 and R3020 without additional modules can be reversed once ordered.

| Item | Description | Part No. | Price |
|---|---|----------------|----------------|
| Minirack dryer 6kW | Electric drying module. Adds 600mm to the length of the Minirack 1400 cubic metres/ hour, 550 watt fan, 6kW of heating power | 915028 | £7,500 |
| Minirack dryer 9kW | Electric drying module. Adds 600mm to the length of the Minirack 1400 cubic metres/ hour, 550 watt fan, 9kW of heating power | 915128 | £8,330 |
| Minirack heat recovery and steam condenser | For cold water feed machines only. Electric fan, 180 watt. 700 cubic metres an hour. No increase to length of machine. Reduces steam released into the environment. Converts potentially wasted energy into 5kW of power to pre-heat incoming water and reduces the power required to run a cold fill machine | 915030 | £6,270 |
| Minirack corner dryer 6kW | Electric corner dryer module – Allows integrated dryer for the tightest corner and U shaped installations. Adds 840mm to the length of the Minirack. 1400 cubic metres/ hour, 550 watt fan, 6kW of heating power | 915028C | £15,160 |
| Minirack corner dryer 9kW | Electric corner dryer module – Allows integrated dryer for the tightest corner and U shaped installations. Adds 840mm to the length of the Minirack. 1400 cubic metres/ hour, 550 watt fan, 9kW of heating power | 915128C | £15,760 |
| Minirack corner prewash | Corner prewash module – Allows integrated prewash for the tightest corner and U shaped installations | R3100 | £3,990 |
| Minirack exhaust fan | Exhaust fan 200 watts, 700 cubic metres/hour. Port 250mm diameter, adds 210mm to machine height | R3 | £1,970 |



Minirack | tabling

Inlet table c/w drain and short splashback.
1200, 1500 or 1800mm long, 700mm deep.
(Right hand as illustrated)

For Left hand inlet:

Only suitable for monoblock
pre rinse spray arm

75451 (1200mm) **£1,370**
75452 (1500mm) **£1,460**
75453 (1800mm) **£1,550**

For Right hand inlet:

75456 (1200mm) **£1,370**
75457 (1500mm) **£1,460**
75458 (1800mm) **£1,550**



Mechanised rack feed corner unit, links to
machines rack drive. Left or right hand.
600 x 650mm



75480 (Left hand) **£1,890**
75481 (Right hand) **£1,890**

Inlet table c/w drain and short splashback.
1200, 1500 or 1800mm long, 700mm deep.
Scrap bin hole. (Right hand as illustrated)

For Left hand inlet:

Only suitable for monoblock
pre rinse spray arm

75446 (1200mm) **£1,540**
75447 (1500mm) **£1,740**
75448 (1800mm) **£1,880**

For Right hand inlet:

75441 (1200mm) **£1,540**
75442 (1500mm) **£1,740**
75443 (1800mm) **£1,880**



Inlet or outlet table, c/w undershelf.
700 or 1100mm long, 600mm deep



75482 (700mm) **£670**
75483 (1100mm) **£670**

Roller exit table, c/w drain and legs.
1100, 1600 or 2100mm long, 630mm
deep includes pair of splash guards



717066 (1150mm) **£1,560**
717067 (1650mm) **£2,040**
717086 (2150mm) **£2,730**

90 degree curved exit roller table,
c/w drain and legs. 1100 x 1100mm



717068 **£2,380**

90 degree powered exit table.
800 x 800mm



75500 **£4,360**

- All tabling is suitable for 500 x 500mm racks
- Supplied flat packed for easy assembly
- All legs supplied with height adjustable feet
- Tables including sinks have **single** ¾" hole for **monoblock** spray arm and 1½" waste
- All sinks are 500mm wide x 400mm front to back x 250mm deep
- All tables with splashback are 745mm deep

RX Evo & Pro Rack Conveyors



- The RX Evo and Pro ranges have evolved from the tried and tested AX range introducing improved efficiency and reliability
- Offers a model to suit all volume warewashing requirements that can be tailored to your specification
- Models are based on modules which include: prewash, single or double main wash, double or triple rinse
- Three drying module options
- Two heat recovery modules options
- Other options include: heat pump, steam condenser, corner inlet and corner dryers
- The range offers the capacity to wash from 83 to 400 racks per hour

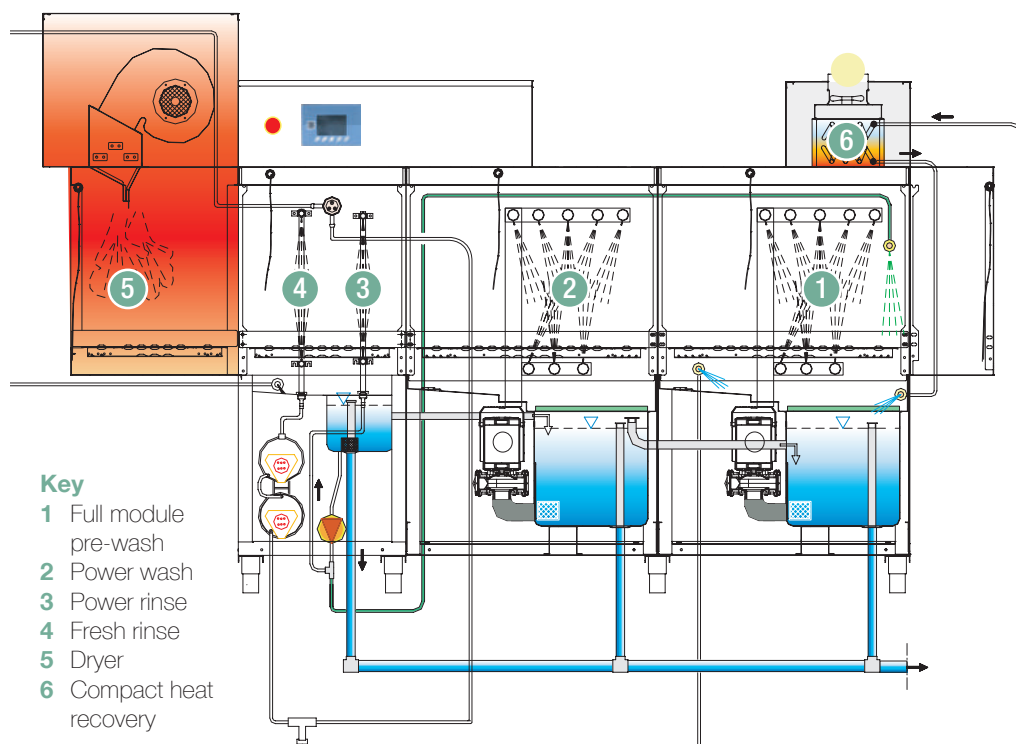

Please note: Rack conveyors are not supplied with rinse aid or detergent dosing as standard, details available on request.

Speak to your Area Sales Manager for a free site survey and quotation relating to your precise site requirements.

RX Evo Rack Conveyors

The RX Evo range now includes 4 base models and one with corner pre-wash with between them the capacity to wash from 83 to 238 racks per hour.

With the option for a full range of additional modules offering corner pre-wash, dryers both inline and corner options, steam x and heat recovery, allow tailor-made solutions.

The RX Evo range is available with traditional electromechanical controls and display fascia or LED control fascia.



RX EVO 184

The RX Evo rack range

| Model | Racks/ Hour | Modules |
|-----------------|-------------|-------------|
| RX 104 | 83/107 | W + RR |
| RX 144 | 92/143 | SP + W + RR |
| RX 184 | 116/190 | MP + W + RR |
| RX 184LC | 116/190 | CP + W + RR |
| RX 244 | 134/238 | LP + W + RR |

SP = Shelf module pre-wash
 MP = Module pre-wash
 CP = Corner module pre-wash
 LP = Long module pre-wash
 W = Wash module
 RR = Pre-rinse & fresh rinse

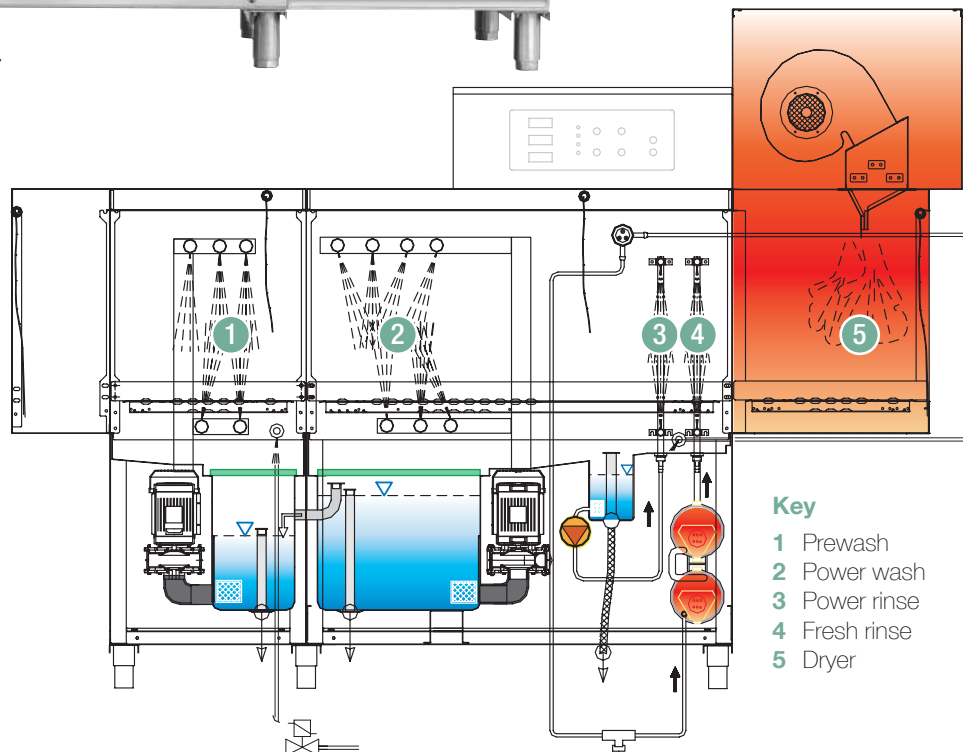

Key

- 1 Prewash
- 2 Power wash
- 3 Power rinse
- 4 Fresh rinse
- 5 Dryer

Due to the ability to tailor the RX Evo range to your requirements please ask your area sales manager to carry out a site survey to ensure the selection of the best arrangement and options and then to provide a site specific quote.

RX Pro Rack Conveyors

The RX Pro range now introduces 5 base models and two with corner pre-wash with between them the capacity to wash from 100 to 400 racks per hour.

The RX Pro range adds the features of multiple rack operating speeds with a comprehensive soft touch LCD control screen, wash arms removable as an

assembly for improved cleaning access and reduced rinse water consumption. Five of the models have the option of an additional pre-wash module with removal draw strainer allowing in-service removal.

With the option for a full range of additional modules offering corner dryers both inline and corner options, steam condenser and heat recovery allow tailor-made solutions.



RX PRO 356

The RX Pro rack range

| Model | Racks/ Hour | Modules |
|-----------------|-------------|-----------------|
| RX 246 | 100/250 | W + 2R |
| RX 296 | 135/300 | P + W + 2R |
| RX 296LC | 135/300 | CP + W + 2R |
| RX 326 | 150/330 | P + W + 2R |
| RX 356 | 190/360 | P + W + W + 2R |
| RX 356LC | 190/360 | CP + W + W + 2R |
| RX 396 | 210/400 | P + W + W + 2R |

- SP = Shelf module pre-wash
- MP = Module pre-wash
- CP = Corner module pre-wash
- LP = Long module pre-wash
- W = Wash module
- 2R = Pre-rinse & fresh rinse module

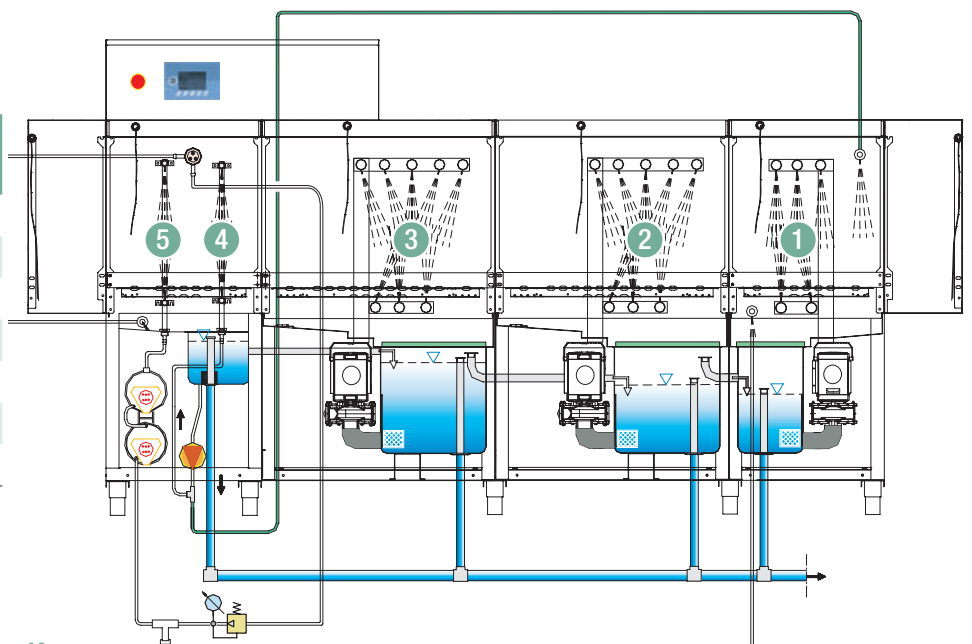

Key

- 1 Prewash
- 2 First power wash
- 3 Second power wash
- 4 Power rinse
- 5 Fresh rinse

Due to the ability to tailor the RX Pro range to your requirements please ask your area sales manager to carry out a site survey to ensure the selection of the best arrangement and options and then to provide a site specific quote.

RX Rack Conveyors | modules

Below is a selection of the extensive range of additional modules available to compliment the RX range of rack conveyors:

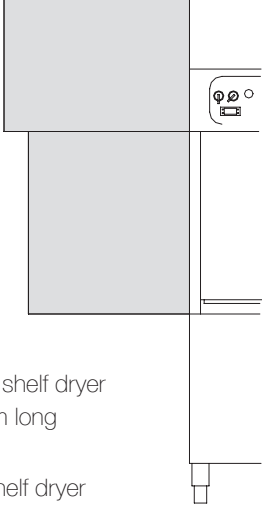
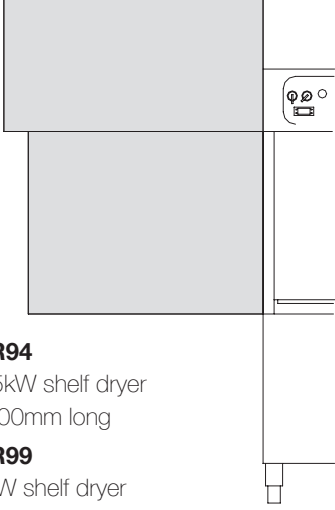
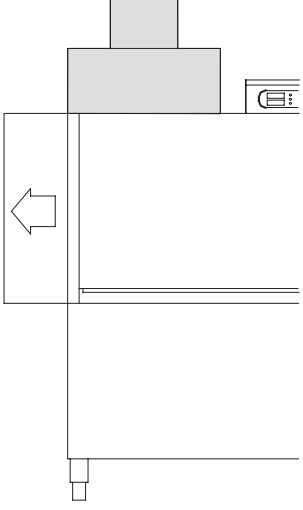
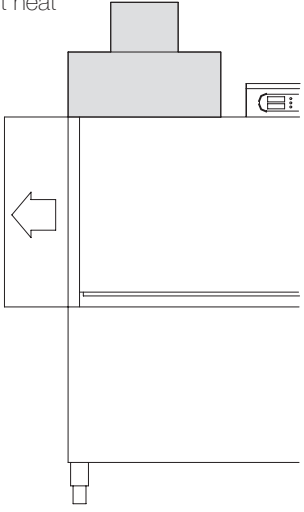
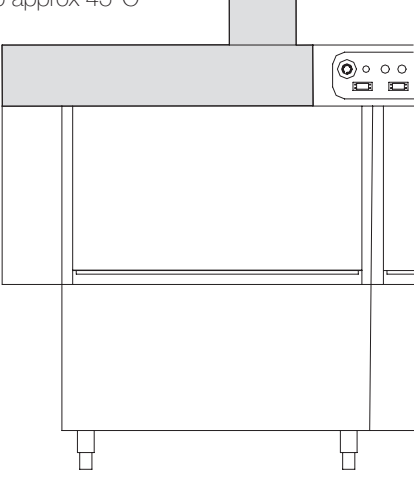
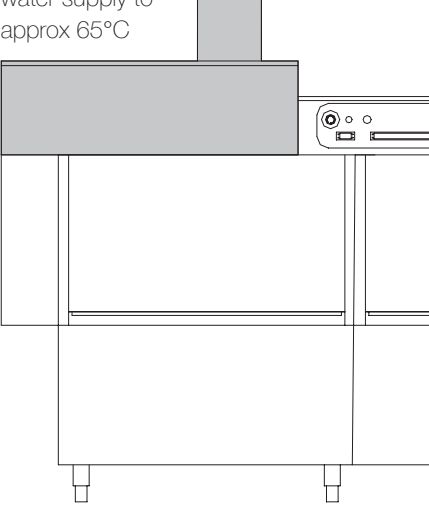
| | | |
|---|---|---|
| <p>Shelf dryer – optimises water removal from any surface</p>  <p>DR64 4.5kW shelf dryer 700mm long</p> <p>DR69 9kW shelf dryer 700mm long</p> | <p>Shelf dryer – longer module for improved drying result</p>  <p>DR94 4.5kW shelf dryer 1000mm long</p> <p>DR99 9kW shelf dryer 1000mm long</p> | <p>Steam condenser – recommended when machine is installed in low-ventilation area</p>  <p>SC10 Steam condenser</p> |
| <p>Compact heat recovery</p>  <p>HR10 Compact heat recovery</p> | <p>Heat recovery – waste heat is used to pre-heat the incoming cold water supply to approx 45°C</p>  <p>HR20 Heat recovery (RX Evo 184/244) (RX Pro 296/396)</p> | <p>Heat recovery with heat pump – waste heat is used to pre-heat the incoming cold water supply to approx 65°C</p>  <p>HRP30 Heat recovery with heat pump (RX Evo 184/244) (RX Pro 296/396)</p> |

Additional modules available for RX range

| Code | Description |
|-----------------|---|
| DRA94MC | 4.5kW 90 degree corner dryer with mechanised drive for RX Evo Range |
| DRA99MC | 9kW 90 degree corner dryer with mechanised drive for RX Evo Range |
| DRA184MC | 4.5kW 180 degree arc dryer with mechanised drive for RX Evo Range |
| DRA189MC | 9kW 180 degree arc dryer with mechanised drive for RX Evo Range |
| DRA94MT | 4.5kW 90 degree corner dryer with motorised drive for RX Pro Range |
| DRA99MT | 9kW 90 degree corner dryer with motorised drive for RX Pro Range |
| DRA184MT | 4.5kW 180 degree arc dryer with motorised drive for RX Pro Range |
| DRA198MT | 9kW 180 degree arc dryer with motorised drive for RX Pro Range |
| SAN | Sanitisation dosing system |
| INSUL | Tank insulation |
| DRINSUL | Dryer insulation |
| BTANK | Breaktank |
| POWER | Additional heating power for cold fill |

Stub roller table c/w drain tank and end stop microswitch 1100 x 650 x 850mm

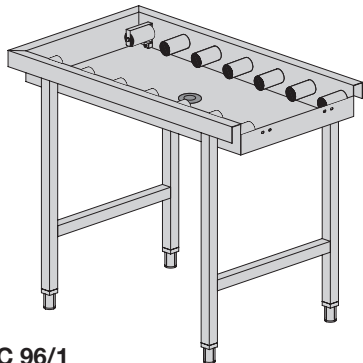

LC 96/1

Stub roller table c/w drain tank and end stop microswitch 1600 x 650 x 850mm

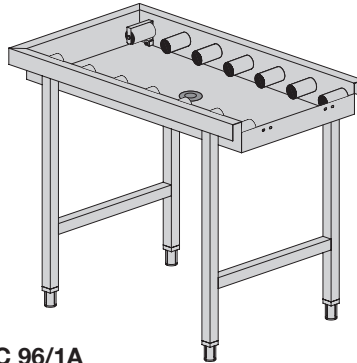

LC 96/1A

90° curved gravity roller table 1300 x 1300 x 850mm

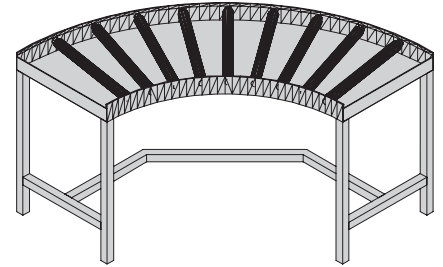

LC 97

90° mechanised curve – self driven 850 x 850 x 850mm

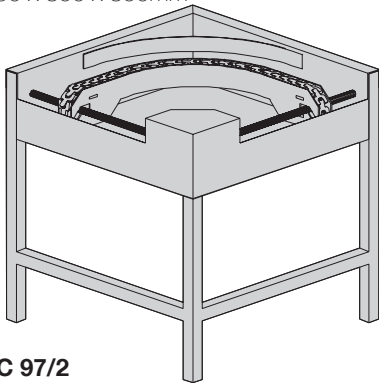

LC 97/2

90° loading table – driven by rack machine 700 x 610 x 900mm

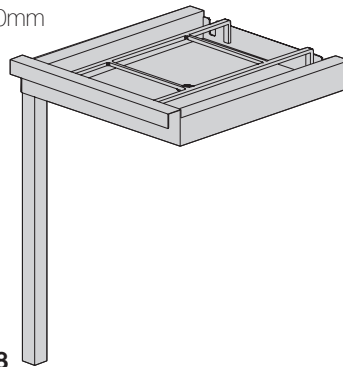

LC98

90° mechanised curve – driven by rack machine 850 x 850 x 850mm

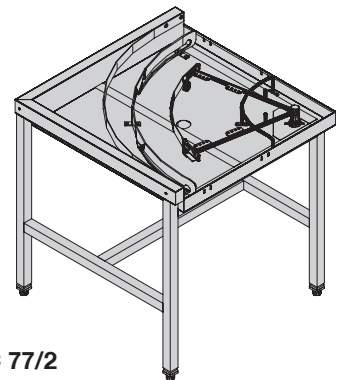

LC 77/2

Plain table c/w sink and splash back 1200 x 730 x 850mm

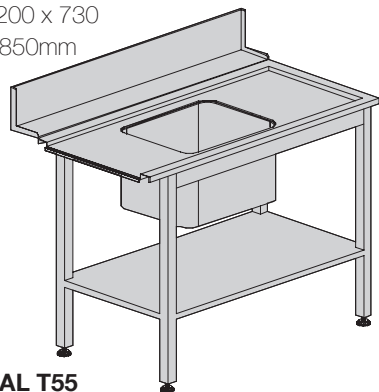

HAL T55

Plain table c/w sink, scrap hole and splash back 1500 x 730 x 850mm

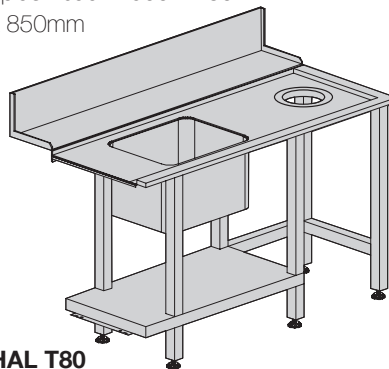

HAL T80

Plain table c/w sink, scrap hole and splash back 1800 x 730 x 850mm

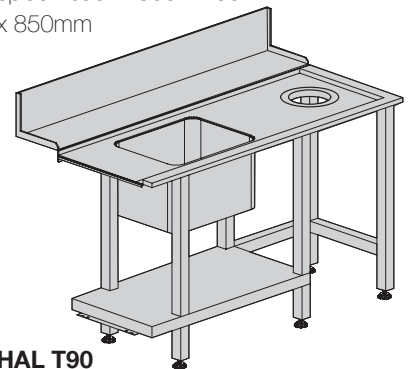

HAL T90

Grading table c/w mechanised basket advance 1800 x 1450 x 1700mm

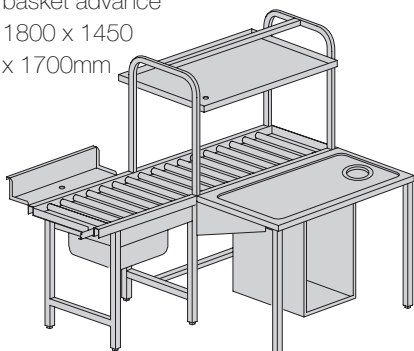

HAL RTC18

Grading table c/w mechanised basket advance 2400 x 1450 x 1700mm

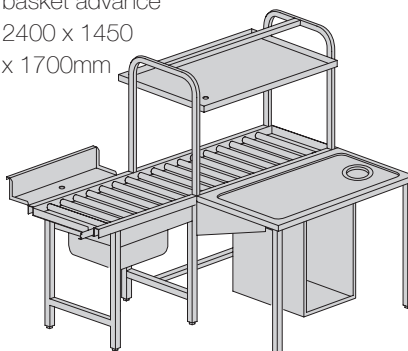

HAL RTC24

The RX range have available a comprehensive range of other tabling options not shown here to suit individual site requirements

QX Flight Machines

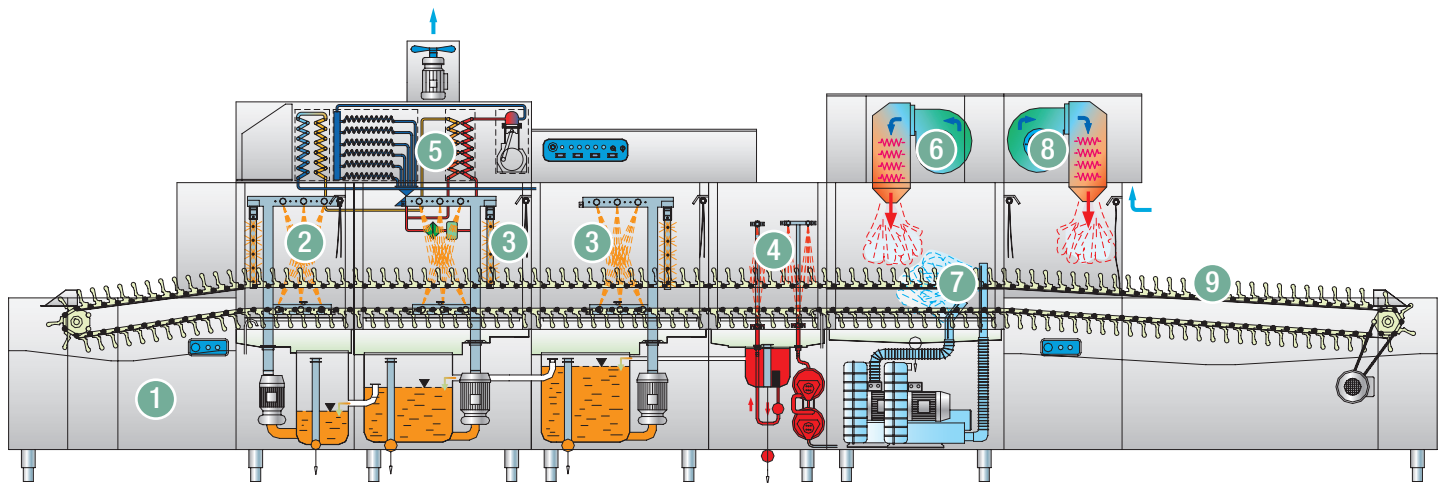

Key

- | | | | | |
|--------------|----------------|--------------------------------|---------------|---------------|
| 1 Inlet zone | 3 Power wash | 5 Heat recovery with heat pump | 6 Stage dryer | 8 Shelf dryer |
| 2 Prewash | 4 Double rinse | 7 Turboblower | 9 Outlet zone | |

- For sites with the heaviest volume of items to wash, inline belt conveyor machines designed for continuous operation
- Extra wide belt of 710mm allows for maximum productivity
- Based on international standard DIN10510 the range offers the ability to wash from 2,400 to a mighty 10,000 plates an hour

- Eight basic arrangements, from 4.5 to 8.2 metres in length. All available for electrical or steam heating
- Additional modules included shelf dryers, stage dryers, neutral zones, heat recovery, heat pumps and steam condensers

Speak to your Area Sales Manager for a free site survey and quotation relating to your precise site requirements.



UT Range

Utensil /
Pot Washers

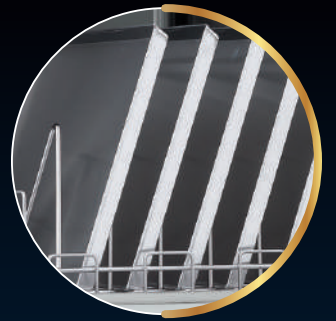

Drain Pump Kits
available on all
Utensil/Potwashers



UT61e /
UT61eHR

UT61He /
UT61HeHR

UT70e /
UT70eHR

UT132e /
UT132eHR

Inserts for pans & trays are not included – see Additional Racks

Easy to use, soft touch keys, complement a large backlit polychromatic LCD display.

The control fascia display offers much more than soft touch buttons, the entire screen changes colour according to the machine status; this makes it easy to read and interpret even from a distance.

YELLOW = is Heating, but will still function



BLUE = in Cycle

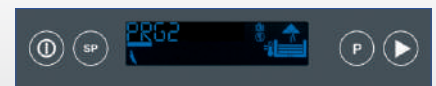

GREEN = Ready to go

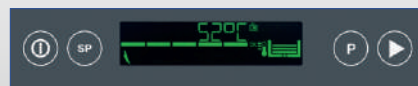

RED = in Alarm

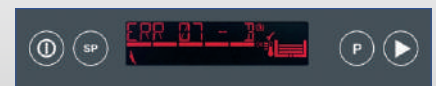

- **1 year warranty**
- Heat Recovery variant available on all models
- **NEW – Drain pump kit available on all models**
- Four button control fascia with special programs button, operational self diagnostics and alarms menu
- Quick release wash/rinse combination arm design on the UT61e & UT61He
- Extensive range of accessories available including a range of trays, gastronorm holders & cutlery rack inserts
- Five standard cycle time options with further options available
- Selectable energy saving mode
- Selectable thermostop ensures optimum rinse temperature
- Precise detergent & rinse aid pumps as standard
- Vertically mounted patented dual flow self draining wash pump – reduces power consumption whilst retaining wash efficiency
- Pressed wash tank carefully designed for easy cleaning
- Internal pressure boosting pump for consistent pressure on rinse cycle
- Double wall split door for easy loading
- Stainless steel sliding rack on easy glide skids
- The sturdy, double-walled AISI 304 stainless steel construction, in addition to guaranteeing long-term reliability, reduces heat loss and noise
- Supplied with one s/s sliding open rack as standard
- Machines are supplied as **gravity drain** unless ordered with drain pump

Technical

- **All models 3 phase and neutral**
- Suitable for hot (max 50°C) or cold water supply at 2 to 4 bar dynamic supply pressure
- Heat Recovery (HR) models cannot be used with hot water supply
- Wash tank temperature – 55°C (adjustable)
- Rinse boiler temperature – 85°C (adjustable)

Machines fitted to cold water supplies will not be capable of running repeated short cycles, the cycle time will automatically be extended to allow recovery of correct operating temperatures.

ANCILLARY PRICES are correct at the point of print, but may vary, please contact our sales team for up to date pricing

| Model | Rack size mm | Useable Height mm | Dimensions mm W x D x H | Cycle Time Mins | Power kW (Amps), Parallel Heating Enabled | Power kW (Amps), Interlocked Heating | Price |
|-----------------|--------------|-------------------|-------------------------|-----------------|---|--------------------------------------|----------------|
| UT61e | 550 x 610 | 650 | 719 x 802 x 1727 | 2 to 12 | 10.5(20)** | 7.5(16) | £10,760 |
| UT61eHR | 550 x 610 | 650 | 719 x 802 x 1957 | 2 to 12 | 10.5(20)** | 7.5(16) | £16,550 |
| UT61He | 550 x 610 | 850 | 719 x 802 x 1927 | 2 to 12 | 10.5(20)** | 7.5(16) | £12,250 |
| UT61HeHR | 550 x 610 | 850 | 719 x 802 x 2157 | 2 to 12 | 10.5(20)** | 7.5(16) | £18,030 |
| UT70e | 700 x 700 | 850 | 853 x 872 x 2063 | 2 to 12 | 18.7(32)** | 10.7(20) | £17,870 |
| UT70eHR | 700 x 700 | 850 | 853 x 872 x 2189 | 2 to 12 | 18.7(32)** | 10.7(20) | £23,640 |
| UT132e | 1320 x 700 | 850 | 1465 x 872 x 2066 | 2 to 12 | N/A | 16(32)** | £28,630 |
| UT132eHR | 1320 x 700 | 850 | 1465 x 872 x 2186 | 2 to 12 | N/A | 16(32)** | £34,400 |

** Standard configuration of machine as supplied. UT61e, UT61He & UT70e models can be reprogrammed to operate interlocked heating during installation to reduce overall loading and amperage requirements.

HEAT RECOVERY MODULE

The heat recovery module is a factory fitted option that is mounted on top of the main body but requires no allowance above the door service clearance height. Full dimensional drawings available for download at maidaid.co.uk or on request.

- Potential to save 30% on power required to heat rinse water (cycle dependent)
- Almost complete elimination of steam release when door opened, dramatically improves working environment
- All cycle times extended by 30 to 60 seconds (model dependent)
- Not for use with osmotic treated water supply, stainless steel version required.

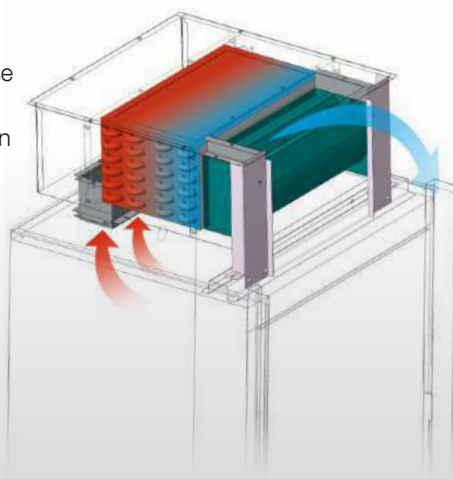

DUAL FLOW WASH PUMP

The patented dual flow wash pump reduces power consumption whilst retaining wash efficiency. Energy savings of up to 20% can be achieved.

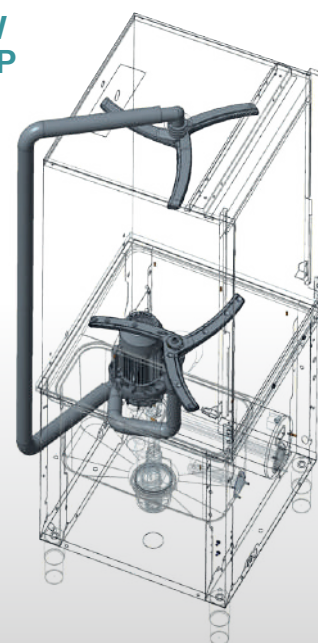

|  UT Range ancillaries | | | MODEL SUITABILITY | | | | | | | |
|--|------------------|----------------|-------------------|---------|--------|----------|-------|---------|--------|----------|
| | | | UT61e | UT61eHR | UT61He | UT61HeHR | UT70e | UT70eHR | UT132e | UT132eHR |
| ANCILLARY DETAILS | PART NUMBER | PRICE | | | | | | | | |
| S/S sliding open rack – 550 x 610mm | MH101489B | £264.00 | ● | ● | ● | ● | | | | |
| S/S sliding open rack – 700 x 700mm | MH104099B | £358.80 | | | | | ● | ● | | |
| S/S sliding open rack – 1320 x 700mm | MH101490B | £658.51 | | | | | | | ● | ● |
| S/S container insert Capacity 8 x 1/1 gastronorm containers – maximum depth 40mm | MH103454B | £187.84 | ● | ● | ● | ● | ● | ● | ● | ● |
| S/S container insert Capacity 5 x 1/1 gastronorm containers – maximum depth 65mm | MH101491B | £222.00 | ● | ● | ● | ● | ● | ● | ● | ● |
| S/S container with cover | MH103453B | £520.00 | ● | ● | ● | ● | ● | ● | ● | ● |
| S/S insert for 2 GN1/1 | MH106114B | £150.29 | ● | ● | ● | ● | ● | ● | ● | ● |
| S/S insert for piping bags and funnels | MH101492B | £73.80 | ● | ● | ● | ● | ● | ● | ● | ● |
| S/S insert for cutlery and utensils | MH103455B | £79.95 | ● | ● | ● | ● | ● | ● | ● | ● |
| Drain Pump Kit | MH106579 | £653.56 | ● | ● | ● | ● | | | ● | ● |
| Drain Pump Kit | MH106580 | £811.54 | | | | | ● | ● | ● | ● |



UT Range ancillaries

See page 47 for model suitability and pricing



MH103453B
S/S container
with cover



MH101489B
S/S sliding open rack
– 550 x 610mm



MH104099B
S/S sliding open rack
– 700 x 700mm



MH101490B
S/S sliding open rack –
1320 x 700mm

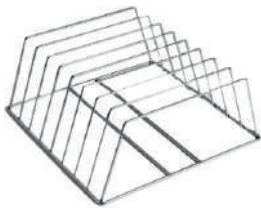

MH103454B
S/S container insert
– capacity 8 x 1/1
gastronorm containers –
maximum depth 40mm



MH101491B
S/S container insert
– capacity 5 x 1/1
gastronorm containers –
maximum depth 65mm

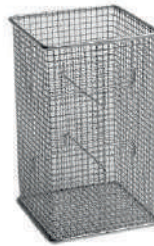

MH103455B
S/S insert for
cutlery and
utensils



MH101492B
S/S insert for
piping bags
and funnels



MH106114B
S/S insert for
2 GN1/1

maidaid 

Where
extraordinary
comes as
standard

- Large stock holdings
- Next day delivery
- Award winning technical support
- Supporting the industry for 50 years
- Nationwide service coverage
- Finance plans



maidaid  **WE'RE HERE TO SUPPORT YOU**

Sales enquiries:
sales@maidaid-halcyon.co.uk

Service & warranty enquiries:
service@maidaid-halcyon.co.uk

maidaid.co.uk



Water Softeners & Ancillaries

Manual Water Softener
Automatic Salt
Regenerated Softener



Water Softeners & Ancillaries

ANCILLARY PRICES are correct at the point of print, but may vary, please contact our sales team for up to date pricing

Manual Water Softener

A manually salt regenerated scale control system, ideal for the protection of glass and dishwashers.

- Four sizes 8 to 20 litre capacity
- Robust construction and easy to install
- Simple to manually regenerate by flushing through a salt solution
- If the correct unit is used then regeneration should not be required more than once a week except in the hardest water areas
- Diameter of all models 185mm
- Softening capacity @ 120 PPM
- Maximum water supply temperature 50°C



| Item | Variants | Capacity (Litres) | Height mm | Part No. | Price |
|--|----------|-------------------|---------------------------|-----------------|----------------|
| Manual Water Softener | 8 litre | 1000 | 420 | Q900008B | £104.53 |
| | 12 litre | 1500 | 520 | Q900012B | £123.14 |
| | 16 litre | 2100 | 620 | Q900016B | £135.92 |
| | 20 litre | 3000 | 920 | Q900020B | £163.17 |
| For correct regeneration it is important that the correct type of salt is used: | | | 2 kg Granular Salt | Q902440B | £4.77 |



Twin Tank Battery Operated Automatic Salt Regenerated Softener

- Twin tank battery operated automatic water softener
- Powered by a single long life 9V lithium battery (included) – Removes need for designated electrical socket
- Battery required to be replaced annually
- Softening capacity @ 300 PPM

| Item | Variants | Capacity (Litres) | Dimensions mm W x D x H | Part No. | Price |
|--|------------|-------------------|--------------------------|-----------------|------------------|
| Twin Tank Battery Operated Automatic Salt Regenerated Softener | Cold Water | 1520 | 269 x 489 x 557 | Q941311B | £963.98 |
| | Cold Water | 3040 | 269 x 489 x 788 | Q941312B | £1,309.29 |
| For correct regeneration it is important that the correct type of salt is used: | | | 25 kg Tablet Salt | Q902441B | £20.06 |



Automatic Salt Regenerated Softener

Automatically salt regenerated scale control, ideal for glass and dishwashers, suitable for establishments that cannot guarantee manual regeneration will be completed.

- Unit regeneration controlled by adjustable time switch, usually set to run when equipment is not required
- Single 13 amp electrical socket required
- Cold water units for 5°C to 50°C, hot water unit for 10°C to 70°C
- Only weekly salt top up required
- Softening capacity @ 300 PPM



| Item | Variants | Capacity (Litres) | Dimensions mm W x D x H | Part No. | Price |
|--|------------|-------------------|--------------------------|------------------|----------------|
| Automatic Salt Regenerated Softener | Cold Water | 1400 | 275 x 485 x 480 | Q900100B | £692.89 |
| | Cold Water | 2300 | 275 x 485 x 555 | Q900101B | £782.12 |
| | Cold Water | 3000 | 275 x 485 x 710 | Q900102B | £785.26 |
| | Hot Water | 2595 | 315 x 510 x 685 | Q900105B* | £765.02 |
| For correct regeneration it is important that the correct type of salt is used: | | | 25 kg Tablet Salt | Q902441B | £20.06 |

*Q900105B



Icemakers

- Cube Icemakers
- Granular Icemakers
- Pebbles Icemakers
- Half Dice Icemakers
- Modular Cube Icemakers
- Slim Bin Cube Icemakers
- Slim Bin Storage Bins
- Storage Bins

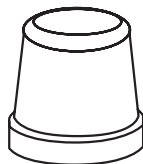

Ø 39mm x H 35mm



CUBE 30-15DP



CUBE 45-20DP



CUBE 60-25DP



CUBE 80-35DP



CUBE 110-60DP



CUBE 150-75DP

- **2 year warranty**
- Supplied with internally fitted drain pump as standard
- Strong door opening system. Door made in stainless steel AISI 304
- STIF: stainless steel fabrication. Solid structure supported in 4 steel columns. AISI 304 stainless steel body
- Environmentally friendly R290 gas which reduces energy consumption
- Smart front ventilation system
- "Never stop" motor pump, designed without seals to prevent deterioration
- Anti-scale spray system. The patented spray system with flexible jets avoids limescale deposits with small vibrations
- Cleaning switch – Aids general servicing and maintenance
- All panels can be disassembled separately which allows easy access from service and installation
- Electronic control that enhances the machine performance
- On/off lighted rocker switch / PCB mounted at the bottom
- Height adjustable legs from 105mm to 155mm
- All machines supplied with 13 amp moulded plug and cable
- Capable of operating in ambient temperatures of 10°C and 43°C
- Supply water temperature between 5°C and 38°C

For maximum production at high ambient temperatures most models are available to special order as water cooled versions.

Technical

- Voltage 230V – single phase – 13 amp
- All models supplied with UK 3 pin moulded plug
- Require water supply pressure between 1 and 6 bar
- Optimum ice production is at an ambient temperature of 21°C. Higher temperatures will dramatically reduce ice production

To produce ice of good quality all ice machines must be supplied with suitably softened and filtered water. Any filters and softeners must be of sufficient capacity and correctly maintained.

| Model | Production Kgs per 24hrs | Cooling System | Standard Cube Size g | Bin Capacity Kgs | Dimensions mm W x D x H (inc. feet) | Drain Height (inc. feet) mm | Water Consumption (air cooled) Litres/H | Price |
|---------------|--------------------------|----------------|----------------------|------------------|-------------------------------------|-----------------------------|---|--------|
| CUBE 30-15DP | 30 | Air Cooled | 22 | 15 | 405 x 515 x 845 | 223 (+50) | 2.9 | £2,060 |
| CUBE 45-20DP | 47 | Air Cooled | 22 | 20 | 465 x 595 x 890 | 239 (+50) | 5.3 | £2,550 |
| CUBE 60-25DP | 55 | Air Cooled | 22 | 25 | 535 x 595 x 890 | 239 (+50) | 5.9 | £3,160 |
| CUBE 80-35DP | 75 | Air Cooled | 22 | 35 | 715 x 595 x 1040 | 239 (+50) | 10.5 | £3,660 |
| CUBE 110-60DP | 112 | Air Cooled | 22 | 60 | 715 x 700 x 1145 | 284 (+50) | 14.1 | £4,280 |
| CUBE 150-75DP | 153 | Air Cooled | 22 | 75 | 860 x 700 x 1145 | 284 (+50) | 20 | £5,360 |



Icemakers | granular



GRANULAR 85-20



GRANULAR 160-64



See page 60 for bin options.



GRANULAR 200

- **2 year warranty**
- Granular 85-20 self contained model that produce dry granular ice
- Granular 160-64 & Granular 200 produce wet granular ice
- Granular 160-64 – head and base supplied separate and must be assembled during install
- Granular 200 requires separate bin
- Environmentally friendly R290 gas which reduces energy consumption
- Efficient evaporator without gasket and seals with lower energy consumption and high ice production
- Stainless steel auger with resilient coating to maximize lifespan and powerful speed reducer on top

- Granular 85-20 with smart front ventilation system, cleaning switch, adjustable feet, stainless steel door & fabrication. Solid structure supported in 4 steel columns which allows easy access for service and installation as all panels can be disassembled separately
- All models with AISI 304 stainless steel body
- Electromechanical control system
- On/Off lighted rocker switch
- All machines supplied with 13 amp moulded plug and cable
- Capable of operating in ambient temperatures of 10°C and 43°C
- Supply water temperature between 5°C and 38°C

For maximum production at high ambient temperatures most models are available to special order as water cooled versions.

Technical

- Voltage 230V – single phase – 13 amp
- All models supplied with UK 3 pin moulded plug
- Require water supply pressure between 1 and 6 bar
- Optimum ice production is at an ambient temperature of 21°C. Higher temperatures will dramatically reduce ice production

To produce ice of good quality all ice machines must be supplied with suitably softened and filtered water. Any filters and softeners must be of sufficient capacity and correctly maintained.

| Model | Production Kgs per 24hrs | Cooling System | Standard Size | Bin Capacity Kgs | Dimensions mm W x D x H (inc. feet) | Water Consumption (air cooled) Litres/H | Price |
|-----------------|--------------------------|----------------|---------------|------------------|-------------------------------------|---|--------|
| GRANULAR 85-20 | 88 | Air Cooled | Granular | 20 | 465 x 595 x 890 | 3.9 | £4,610 |
| GRANULAR 160-64 | 164 | Air Cooled | Granular | 64 | 515 x 550 x 1415 | 6.8 | £5,200 |
| GRANULAR 200 | 211 | Air Cooled | Granular | N/A | 515 x 550 x 486 | 9.6 | £5,350 |

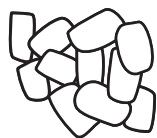

PEBBLE 240-40

- **2 year warranty**
- Produces pebble ice
- Environmentally friendly R290 gas which reduces energy consumption
- Strong door opening system, door made in stainless steel AISI 304
- Strong stainless steel fabrication. Solid structure supported in 4 steel columns which provides easy access for service and installation as all panels can be removed separately
- High evaporator efficiency, lower energy consumption and higher ice production

- Smart front ventilation system
- Stainless steel auger with resilient coating to maximise lifespan
- Electronic control – On/Off lighted rocker switch and auto diagnostics signalling operation status and alerts
- Height adjustable legs from 105mm to 155mm
- All machines supplied with 13 amp moulded plug and cable
- Capable of operating in ambient temperatures of 10°C and 43°C
- Supply water temperature between 5°C and 38°C

Technical

- Voltage 230V – single phase
- Require water supply pressure between 1 and 6 bar
- Optimum ice production is at an ambient temperature of 21°C. Higher temperatures will dramatically reduce ice production

To produce ice of good quality all ice machines must be supplied with suitably softened and filtered water. Any filters and softeners must be of sufficient capacity and correctly maintained.

| Model | Production Kgs per 24hrs | Cooling System | Standard Size | Bin Capacity Kgs | Dimensions mm W x D x H (inc. feet) | Drain Height (inc. feet) mm | Water Consumption (air cooled) Litres/H | Price |
|---------------|--------------------------|----------------|---------------|------------------|-------------------------------------|-----------------------------|---|--------|
| PEBBLE 240-40 | 240 | Air Cooled | Pebble | 40 | 715 x 755 x 1145 | 284 (+50) | 10 | £9,270 |



HALF DICE 220

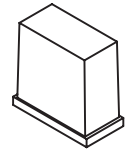

W 23mm x D 11mm x H 26mm



HALF DICE 410

See page 60 for bin options.

- **2 year warranty**
- Both machines produce half dice 6 gram ice cubes
- Half dice 220 uses environmentally friendly R290 gas which reduces energy consumption
- Half dice 410 uses R452A refrigerant
- High resistance external frame as AISI 304 stainless steel which aids service installation and maintenance

- Highly efficient evaporator
- Smart water distributor that improves drop-off efficiency
- Smart electronic board with self-diagnostics
- Capable of operating in ambient temperatures of 10°C and 43°C
- Supply water temperature between 5°C and 38°C

For maximum production at high ambient temperatures most models are available to special order as water cooled versions.

Technical

- Half dice 220 – 230V supplied with 13 amp moulded plug and cable
- Half dice 410 – three phase 16 amp
- Requires water supply pressure between 1 and 6 bar
- Optimum ice production is at an ambient temperature of 21°C. Higher temperatures will dramatically reduce ice production

To produce ice of good quality all ice machines must be supplied with suitably softened and filtered water. Any filters and softeners must be of sufficient capacity and correctly maintained.

| Model | Production Kgs per 24hrs | Cooling System | Standard Cube Size g | Dimensions mm W x D x H | Water Consumption (air cooled) Litres/H | Price |
|----------------------|--------------------------|----------------|----------------------|-------------------------|---|---------------|
| HALF DICE 220 | 207 | Air Cooled | 6 | 762 x 620 x 500 | 12 | £4,960 |
| HALF DICE 410 | 405 | Air Cooled | 6 | 762 x 620 x 760 | 17 | £6,620 |

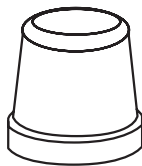

Ø 35mm x H 35mm
CUBE 150 & CUBE 350

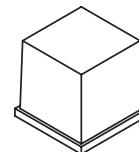

W 26mm x D 23mm x H 26mm
CUBE 300 only



CUBE 150



CUBE 350



CUBE 300
SLIM



See page 60 for bin options.

- **2 year warranty**
- CUBE 300 SLIM also available to order in Half Dice 6 gram cubes – standard cube size W 26mm x D 23mm x H 26mm
- CUBE 150 and CUBE 300 SLIM use environmentally friendly R290 gas which reduces energy consumption
- CUBE 150 and CUBE 350 use an anti-scale patented spray system with flexible jets which avoids deposits with small vibrations
- CUBE 350 uses R452A refrigerant

- High resistance external frame as AISI 304 stainless steel which aids service installation and maintenance
- Highly efficient evaporator
- Smart water distributor that improves drop-off efficiency
- Smart electronic board with self-diagnostics
- Capable of operating in ambient temperatures of 10°C and 43°C
- Supply water temperature between 5°C and 38°C

For maximum production at high ambient temperatures most models are available to special order as water cooled versions.

Technical

- CUBE 150 & CUBE 300 SLIM 230V single phase 13 amp supplied with moulded plug and cable
- CUBE 350 – 230V single phase 25 amp
- Require water supply pressure between 1 and 6 bar
- Optimum ice production is at an ambient temperature of 21°C. Higher temperatures will dramatically reduce ice production

To produce ice of good quality all ice machines must be supplied with suitably softened and filtered water. Any filters and softeners must be of sufficient capacity and correctly maintained.

| Model | Production Kgs per 24hrs | Cooling System | Standard Cube Size g | Dimensions mm W x D x H | Water Consumption (air cooled) Litres/H | Price |
|---------------|--------------------------|----------------|----------------------|-------------------------|---|--------|
| CUBE 150 | 150 | Air Cooled | 22 | 775 x 625 x 805 | 22 | £5,120 |
| CUBE 350 | 345 | Air Cooled | 22 | 1321 x 638 x 993 | 24.4 | £9,320 |
| CUBE 300 SLIM | 305 | Air Cooled | 12 | 559 x 621 x 659 | 16.6 | £6,200 |



ICE FD215

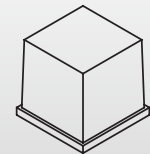

W 26mm x D 23mm x H 26mm

- **2 year warranty**
- Modular cube machine with highly efficient evaporator
- Smart water distributor that improves drop off efficiency
- Smart electronic board
- Environmentally friendly R290 gas
- Stainless steel construction

Technical

- Require water supply pressure between 1 and 6 bar
- Optimum ice production is at an ambient temperature of 21°C. Higher temperatures will dramatically reduce ice production

To produce ice of good quality all ice machines must be supplied with suitably softened and filtered water. Any filters and softeners must be of sufficient capacity and correctly maintained.

| Model | Production Kgs per 24hrs | Cooling System | Standard Cube Size g | Dimensions mm W x D x H | Water Consumption (air cooled) Litres/H | Price |
|-----------|--------------------------|----------------|----------------------|-------------------------|---|--------|
| ICE FD215 | 207 | Air Cooled | 12 | 762 x 620 x 500 | 11.1 | £4,650 |

See page 60 for compatible bin options.



See pages 61-62 for ancillary items.

Maidaid®
slim bin | Ice cube
modular
range



Don't forget
to order your
Storage Bin
– see page 59
for options.



SLIM132



SLIM192



SLIM195E

(Illustration shown with
storage bin MSB105 –
not included)

- 12 months warranty
- 560mm wide units for small spaces
- Soft touch control panel
- Standard cube 10 gram 22 x 22 x 24mm
- Slim195E hydrocarbon with zero environmental impact
- Half cube 6 gram and large cube 17 gram available to special order
- Vertical evaporation design
- Excellent service accessibility
- Works in ambient temperatures between 10°C and 40°C
- Supply water temperature between 5°C and 35°C

For maximum production at high ambient temperatures models SLIM132 & 192 are available to special order as water cooled versions at the same price.

All slim bin modular units will require an ice storage bin, see page 59.

Technical

- Voltage 230V – single phase
- Slim 132 – 13 amp
- Slim 192 & 195E – 16 amp
- 1 to 5 bar operating water pressure
- Optimum production is achieved at ambient and water supply temperatures of 21°C and 10°C
- Ambient and water supply temperature will affect ice production capacity

To produce ice of good quality all ice machines must be supplied with suitably softened and filtered water. Any filters and softeners must be of sufficient capacity and correctly maintained.

| Model | Production Kgs per 24hrs | Dimensions mm W x D x H (inc. feet) | Drain Height mm | Water Consumption (air cooled) Litres/Hour | Water Consumption (water cooled) Litres/Hour | Gross Weight Kgs | Power kW (Max Amps)** | Price |
|----------|--------------------------|-------------------------------------|-----------------|--|--|------------------|-----------------------|--------|
| SLIM132 | 143 | 560 x 620 x 575 | 43 | 6 | 61.3 | 65 | 1.64(13A) | £4,810 |
| SLIM192 | 212 | 560 x 620 x 660 | 44 | 8.5 | 126 | 80 | 2.35(16A) | £5,450 |
| SLIM195E | 210 | 560 x 620 x 660 | 43 | 9.2 | N/A | 78 | 2.84(16A) | £5,730 |

Height of drain is for modular unit only, add height of bin for overall height.

When in ice production mode.

** During harvest cycle the unit draws a higher current, failure to fuse correctly may result in equipment failure.

See pages 61-62 for ancillary items.



MSB105



MSB155



MB255



Suitable for Maidaïd® SLIM production units only – see page 58.

(Illustration shows SLIM195E with storage bin MSB105 – both to order separately.)

- **12 months warranty**
- Two slim bins 560mm wide for small spaces
- One bin for larger capacity ice storage
- All MSB bins suitable for any Maidaïd® SLIM production unit
- High thermal efficiency ice storage bins fully stainless steel body construction
- Polyethylene lid with gasket seal, self-latching in open position for easy ice retrieval

| Model | Storage capacity | Dimensions mm W x D x H (inc. legs) | Suitable production unit | Price |
|---------------|------------------|--|----------------------------|---------------|
| MSB105 | 129 | 560 x 845 x 1050 | SLIM132, SLIM192, SLIM195E | £1,790 |
| MSB155 | 168 | 560 x 865 x 1275 | SLIM132, SLIM192, SLIM195E | £2,040 |
| MB255 | 243 | 765 x 870 x 1275 | SLIM132, SLIM192, SLIM195E | £2,400 |

Icemakers | storage bins



BIN 130



BIN 220



BIN 160



BIN 400

- **2 year warranty**
- AISI 304 stainless steel bins
- High quality, durable polyethylene internal basin, resistant to blows and scratches
- Easy cleaning design: Seamless one-piece vat with rounded corners, avoiding possible dirty points and facilitating cleaning
- Drainage system that collects and drives the water to the drain keeping the bin clean & dry

| Model | Storage Capacity Kgs | Dimensions mm W x D x H (inc. feet) | Suitable Modular Icemaker Models | Price |
|----------------|----------------------|-------------------------------------|--|---------------|
| BIN 130 | 130 | 765 x 802 x 900 | CUBE 150, GRANULAR 200, HALF DICE 220, HALF DICE 410, ICE FD215, CUBE 300 SLIM | £2,050 |
| BIN 160 | 160 | 559 x 872 x 1242 | GRANULAR 200, ICE FD215, CUBE 300 SLIM | £2,210 |
| BIN 220 | 200 | 762 x 819 x 1224 | CUBE 150, GRANULAR 200, HALF DICE 220, HALF DICE 410, ICE FD215, CUBE 300 SLIM | £2,310 |
| BIN 400 | 350 | 1219 x 819 x 1226 | CUBE 150, CUBE 350, GRANULAR 200, HALF DICE 220, HALF DICE 410, ICE FD215, CUBE 300 SLIM | £3,290 |

To achieve the best result from any Midea® icemaker it is important that the machine is supplied with high quality water. To achieve this it is strongly advised that from installation the machine is installed with a correct filter and softener as required. The grid below provides a guide to Midea's recommendations, due to the variations in water hardness and mineral contents the suggested filters and softeners cannot be guaranteed to provide the correct level of protection required.

All kits include – connection head, filter cartridges, and food safe two connection hoses.

| MODEL SUITABILITY | Miniphos Scale Inhibitor | Filter Kit 50 | Filter Kit 200 | Filter Kit 400 | Filter Kit 200 Dual | Water softener |
|-------------------|--------------------------|------------------------|-------------------------|-------------------------|--------------------------|-------------------------|
| | Part Number: Q900400B | Part Number: FILTKIT50 | Part Number: FILTKIT200 | Part Number: FILTKIT400 | Part Number: FILT2KIT200 | Part Number: SOFTICEKIT |
| | Price: £45.38 | Price: £111.74 | Price: £157.63 | Price: £195.42 | Price: £415.18 | Price: £580.85 |
| CUBE 30-15DP | ● | ● | | | | ● |
| CUBE 45-20DP | | ● | | | | ● |
| CUBE 60-25DP | | ● | | | | ● |
| CUBE 80-35DP | | | ● | | | ● |
| CUBE 110-60DP | | | ● | | | ● |
| CUBE 150-75DP | | | ● | | | ● |
| CUBE 150 | | | ● | | | ● |
| CUBE 350 | | | | ● | ● | ● |
| CUBE 300 SLIM | | | | ● | ● | ● |
| GRANULAR 85-20 | | | | ● | ● | ● |
| GRANULAR 160-64 | | | | ● | ● | ● |
| GRANULAR 200 | | | | ● | ● | ● |
| PEBBLE 240-40 | | | | ● | ● | ● |
| HALF DICE 220 | | | | ● | | ● |
| HALF DICE 410 | | | | ● | | ● |
| ICE FD215 | | | | ● | | ● |
| SLIM132 | | | ● | | | ● |
| SLIM192 | | | ● | | | ● |
| SLIM195E | | | ● | | | ● |

Icemaker ancillaries and replacement cartridges



(All filters and softener cartridges should be changed every 6 months)

| Item | Part Number | Price | Item | Part Number | Price |
|---|-------------|---------|----------------------|-------------|---------|
| Universal Machine Stand | Q902100B | £94.29 | Filter cartridge 50 | Q900420B | £51.17 |
| Drain/Condensate pump | Q904200B | £166.33 | Filter cartridge 200 | Q900421B | £99.58 |
| | | | Filter cartridge 400 | Q900422B | £149.84 |
| Miniphos Refill Marble and Filter Pack | Q900401B | £16.19 | Softener cartridge | Q900450B | £507.11 |

Icemaker ancillaries



See page 61 for details of icemaker model suitability and pricing



Q900400B

Miniphos scale inhibitor



FILTKIT50 Filter Kit 50



FILTKIT200 Filter Kit 200



Q900450B

Softener cartridge



FILTKIT400 Filter Kit 400



FILT2KIT200

Filter Kit 200
Dual



Q904200B

Drain/condensate pump

FILTER DIMENSIONS

| Item | Part Number | Height mm | Diameter mm |
|----------------------|-------------|-----------|-------------|
| Filter cartridge 50 | Q900420B | 370 | 80 |
| Filter cartridge 200 | Q900421B | 525 | 80 |
| Filter cartridge 400 | Q900422B | 635 | 80 |
| Filter cartridge 4FC | Q900425B | 370 | 80 |
| Softener cartridge | Q900450B | 475 | 175 |

| Mounting Head | Width mm | Height mm | Depth (from wall) mm |
|---|----------|-----------|----------------------|
| Single cartridge head and mounting bracket (without fittings) | 85 | 62 | 105 |
| Dual cartridge head and mounting bracket (without fittings) | 440 | 215 | 150 |
| Softener head and mounting bracket (without fittings) | 100 | 140 | 125 |

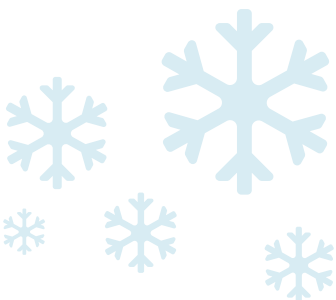



Icemakers

Maidaid offers an extensive range of ice styles in a wide range of production capacities.

Specialists in warewashing and ice machines



Undercounter & Pass Through Machines

Models to suit every application, from a hospital cafeteria to a university bar.



Utensil / Pot Washers

Advanced design 'Smart' soft touch electronic user interface.



Minirack Dishwashers

Market leading rack machines: a proven design.



Exclusively from Maidaid distributors.
For more information 0345 130 8070

maidaid.co.uk



Maidaid

The Engine Shed, Top Station Road
Brackley, Northants NN13 7UG

Telephone **0345 1308070**
Sales email **sales@maidaid-halcyon.co.uk**
Service email **service@maidaid-halcyon.co.uk**
Web **maidaid.co.uk**

Your Local Distributor

122152.001



Quality Control

Quality of product and after-sales service is based on the operation of systems to the internationally recognised quality standards BS EN ISO 9001 and BS EN ISO 14001. However, above all else, quality of service results from the abilities, motivation and teamwork of people within the company.

